

**Robinsons**  
Premier Aluminium  
**GREENHOUSES**

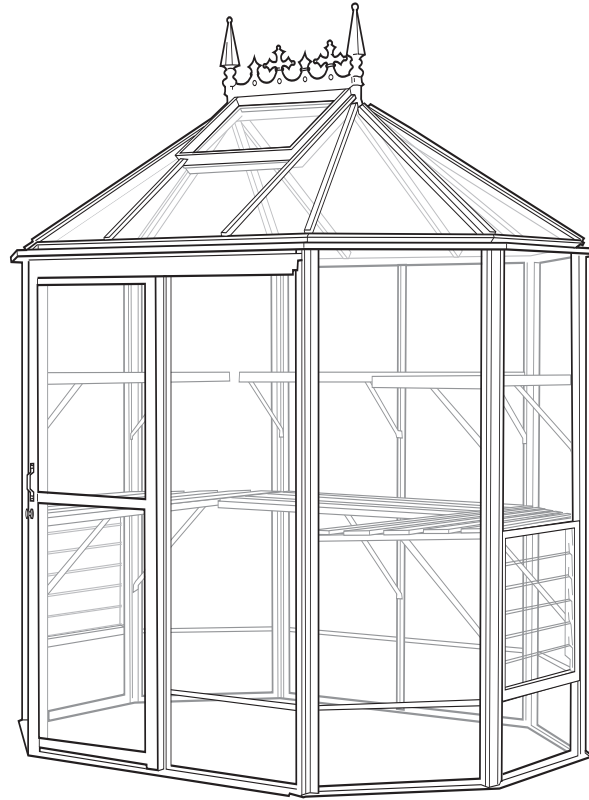

## Renaissance

### Assembly Instructions for models 68 · 610 · 612

**GREENHOUSE**

**BEFORE OPENING ANY OF THE BOXES PLEASE READ THESE INSTRUCTIONS**

# RENAISSANCE Greenhouse Base Plan

You may have already considered the position of your new Robinsons Greenhouse and be aware of the importance of a square and level base.

We cannot emphasise how important it is to have a proper base. It is essential that the base is flat, level and square as well as being substantial enough to take the weight of the greenhouse including 4mm toughened glass.

If not already completed the base should ideally be a concrete perimeter footing a spade's width and of sufficient depth for your local ground conditions. A brick perimeter base is equally suitable (and more attractive) providing there is a suitable concrete foundation beneath it.

A quality stock brick or semi-engineering brick is recommended. The dimensions given for the greenhouse base plan allow the building to overhang the base in order to help prevent water running back into the building. If you are using a flat slab base, which may be easier to prepare, then you may get water seeping underneath. You can apply a watertight sealant between the bottom rail and the base if required. (Not supplied)

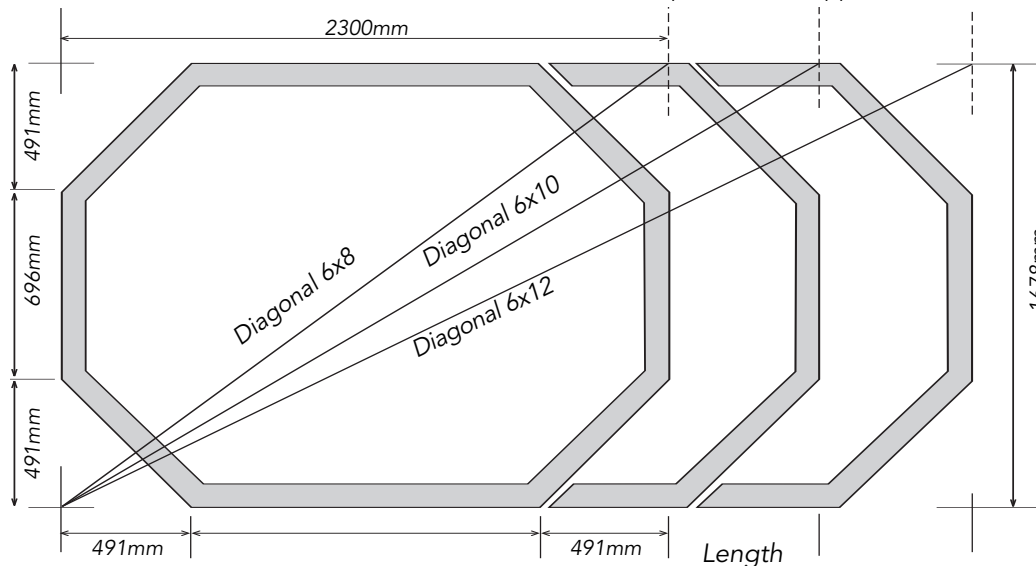

## EXTERNAL DIMENSIONS (mm)

MODEL	Width	Length	Diagonal
6 x 8	1678	2300	2847
6 x 10	1678	2920	3367
6 x 12	1678	3540	3917

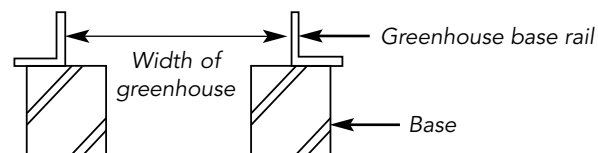

## Safety Advice

It is advisable that two people should assemble this greenhouse. Particular care should be taken when handling glass and the wearing of gloves is strongly recommended. Favourable weather conditions should be chosen. Do not try to erect the building in windy conditions.

Keep children and pets away until the work is finished.

Take your time - rushing causes accidents.

## Tools required

- Step ladders 2m high (*two if possible*)
- Spanners or 10mm socket
- Drill + bits including 7mm masonry
- Spirit Level
- Screwdriver, manual or power with attachments
- Sharp scissors or knife
- Gloves

# Robinsons

PREMIER ALUMINIUM GREENHOUSES

# RENAISSANCE

Example model: 6 x 8 Renaissance

Please refer to the Parts List at the back of this manual to help you identify specific items during assembly

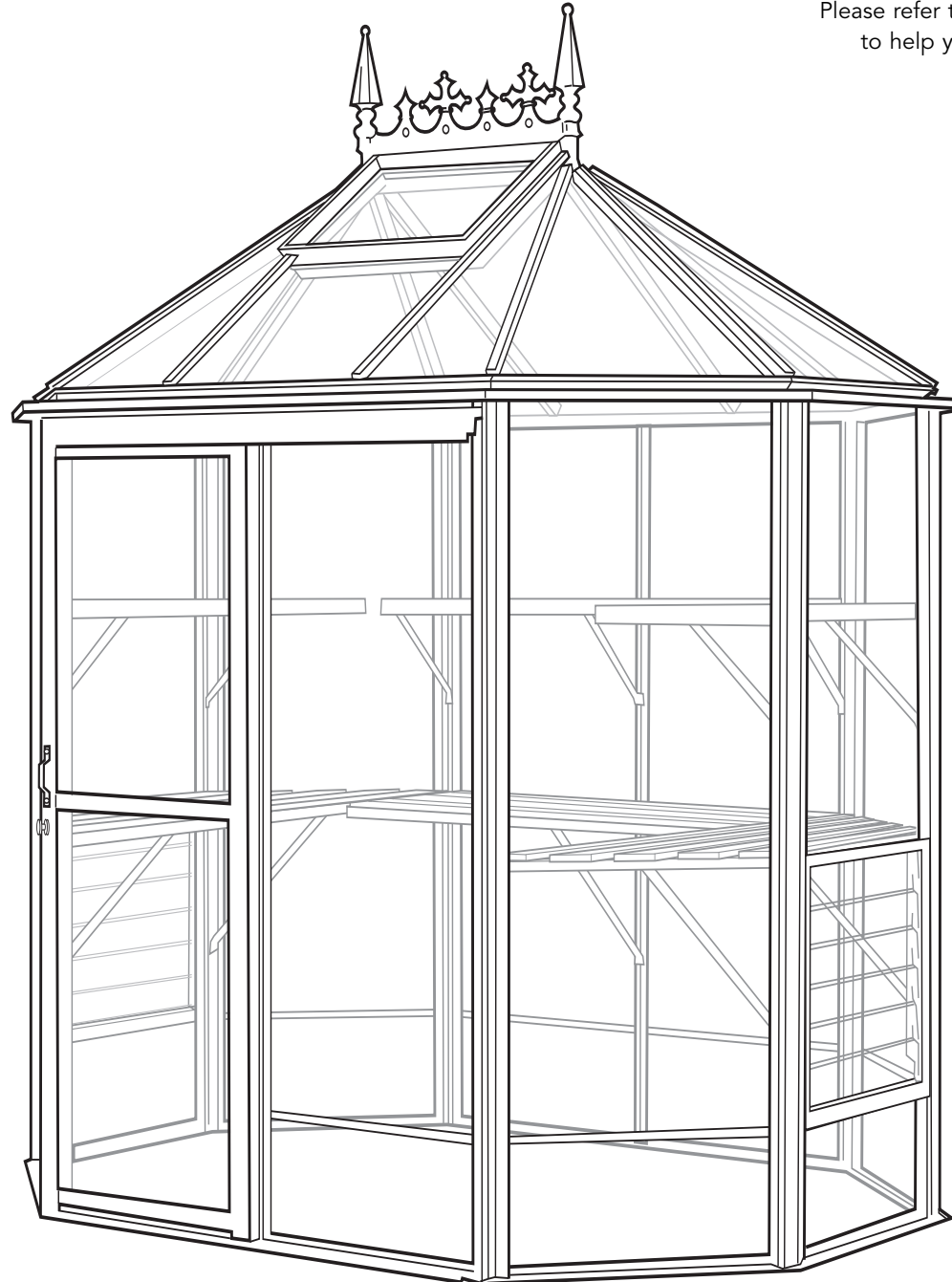

# RENAISSANCE - PRE ASSEMBLY

Before starting the assembly of your new greenhouse please read these instructions carefully. Check that all parts have been delivered against the parts list.

Once happy with the instructions start by locating eight Corner Glazing Bars, (3) 1930mm in length, plus the roll of the PVC Glazing Strip.

NOTE: All the threading of the glazing strips - including both the side and roof glazing bars - can be done prior to assembly, perhaps in the relative comfort of a garage or shed.

Using a little drop of washing up liquid at the start, thread the PVC glazing strip into both grooves in all the corner glazing bars. (See diagram 3). In all cases cut to full length taking care not to stretch the PVC strip. A little overlap may be advisable, this can be trimmed while assembling.

## ASSEMBLY

We are now going to assemble four identical end panels (1,2,3 and 4-see plan). You will need to locate a Short Base Angle, (1) a Hip Gutter (2) and two base brackets for each panel. Loosely fix a 15mm long bolt and nut in each hole of the base Angle, and a 10mm bolt and nut to the Gutter. See diagram.

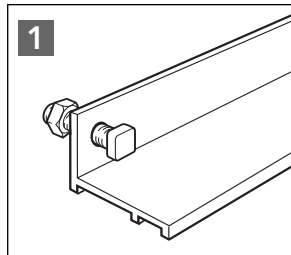

Short Base Angle

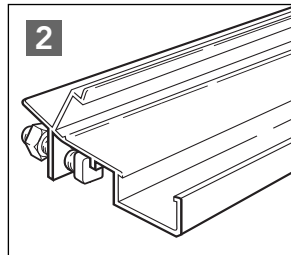

Short Hip Gutter

For ease lay these parts, in position, on the ground, as if viewed from inside the greenhouse, per the plan. Ensure suitable protection is put down if the surface is likely to scratch the coating/paint.

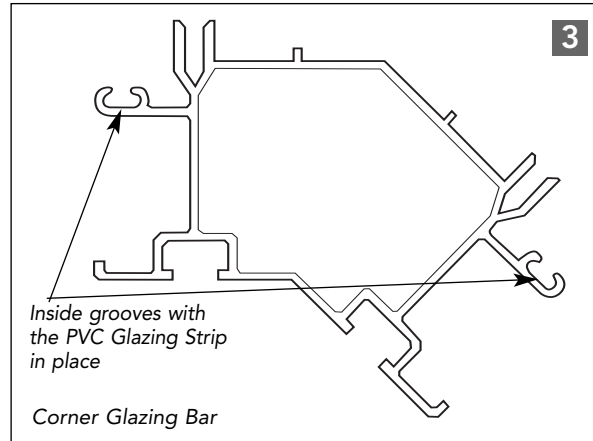

Inside grooves with the PVC Glazing Strip in place

Corner Glazing Bar

Fix the two Corner Glazing Bars with the base brackets, (using the elongated hole, and on the inside of the greenhouse) and base rail (see diagram 5) and tighten the nuts firmly. Next connect the Gutter (4) to the Corner Glazing Bars - to form a frame - the corner glazing bar is to rest on the 'lip' on the inside of the gutter.

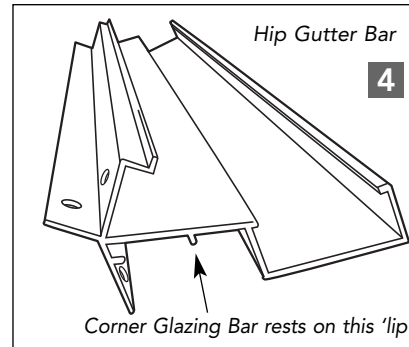

Hip Gutter Bar

Corner Glazing Bar rests on this 'lip'

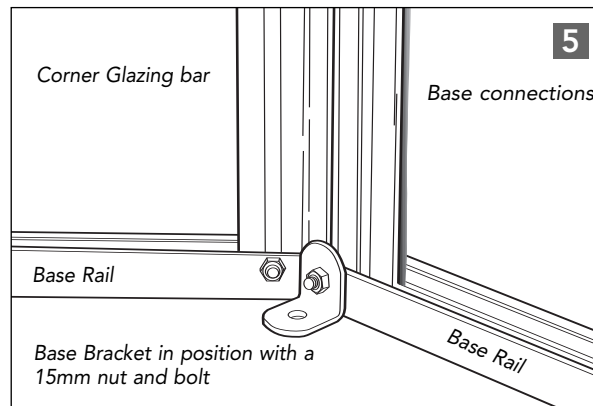

Corner Glazing bar

Base connections

Base Rail

Base Bracket in position with a 15mm nut and bolt

Base Rail

Check all nuts are tight but be careful not to overtighten.

Now repeat the same process on remaining three panels.

**IMPORTANT** You will require two strong step ladders for this part of the assembly. If this is not possible then extra people to hold sections in place is essential.

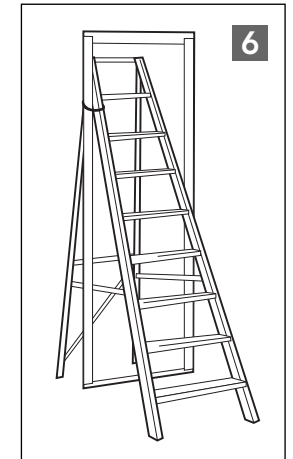

You will require the remaining two base angles and hip gutters plus the appropriate nuts and bolts. Trim any access PVC glazing strip prior to assembly.

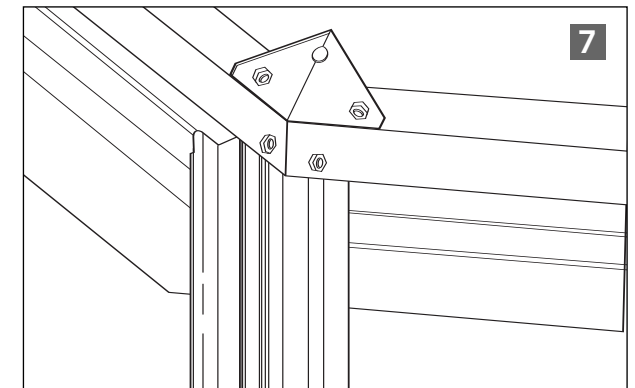

Carefully support the first of the made panels in an upright position (6) - by fastening it to the step ladders, or a second person holding it. Connect both the base angle and gutter to the supported panel with 10mm nuts and bolts, in the previously described way. Next, position the second completed panel and secure with correct nuts and bolts. (Eg connect sections 1 to 2 and 3 to 4)

# RENAISSANCE - ASSEMBLY PLAN

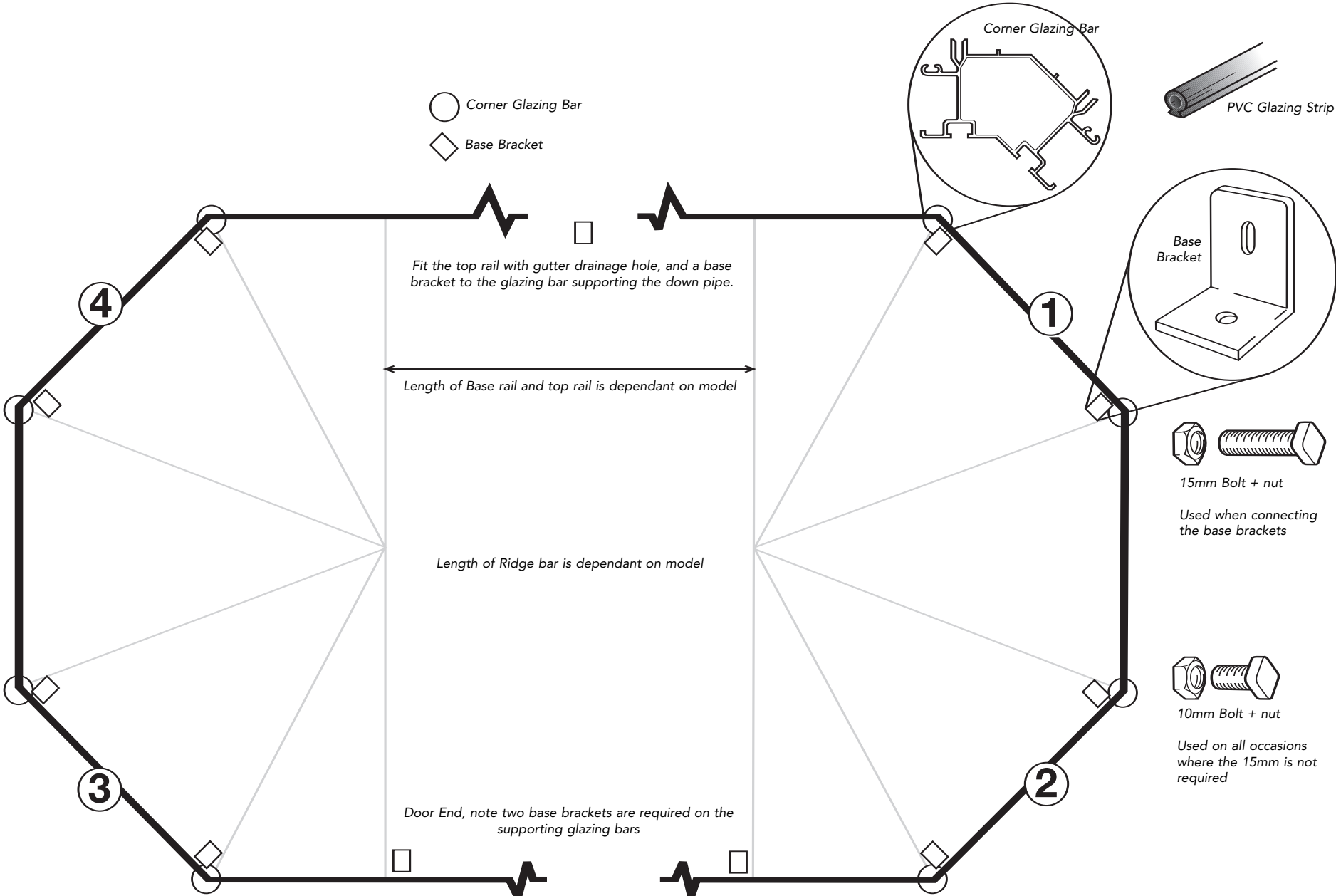

# RENAISSANCE - CONNECTING THE SIDES

On the top connecting point of each corner glazing bar, place and secure the triangular eaves bracket with two 10mm nuts and bolt - see diagram 7.

Repeat this operation for the other end. You should now have the two angled end sections complete. Check all nuts are tight but be careful not to overtighten.

The sections can now be positioned in the final position. If the greenhouse is being placed on an oversized based, eg slabs, a waterproof sealant (NOT SUPPLIED) can be applied to the base if required. It is not essential, but water seepage may occur.

Place the two base rails (length dependant on model) roughly in position and adjust into final place with the end sections, secure together with 10mm nuts and bolts. Next secure the top rail in a similar manner. Note: the top rail with the gutter drainage hole should be located at the back of the greenhouse - opposite the doorway.

This should now be the basic framework of the greenhouse. Check the final position of your greenhouse. Any manoeuvring should be done with care and two persons. At this stage check that all nuts are firm. Minor adjustments may be require when fitting the glass, but it is important that the frame is sturdy and square.

## SIDE GLAZING BARS

If not already done so thread the PVC Glazing Strip into the side glazing bars. Diagram 9.

- 612 Model will have five glazing bars
- 610 Model will have three glazing bars
- 68 Model will have two glazing bars

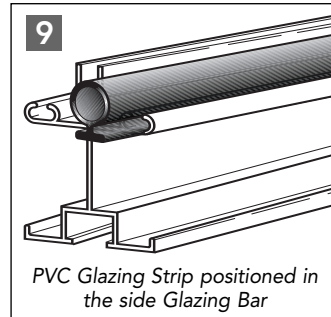

PVC Glazing Strip positioned in the side Glazing Bar

Note that the glazing bars adjacent to the door will only require the pvc glazing strip in the inner groove. See diagram 8 at the bottom of page.

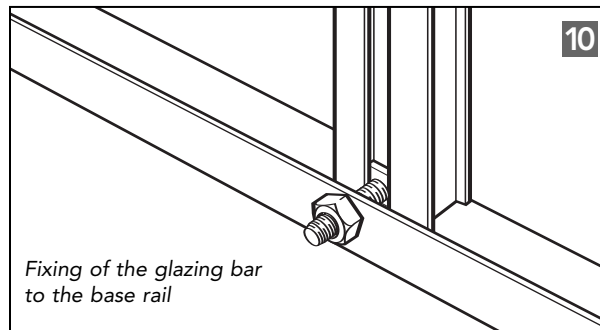

Fixing of the glazing bar to the base rail

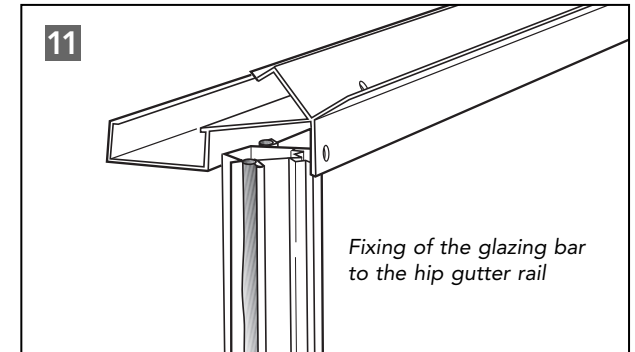

Fixing of the glazing bar to the hip gutter rail

The glazing bar supporting the door and the centre bar on the back should also have a base bracket fixed with 15mm nuts and bolts, (as previously stated).

Depending on model the remaining bars should be secured in position with 10mm nuts and bolts, dia.10,11.

## ROOFING GLAZING BARS

Again if not already done so thread the PVC glazing strips in all the roofing glazing bars. Diagram 12

There are two sorts of roofing bars which need to be identified prior to assembly. The shorter 'square' version (A) will be used on the straight ridge sections. The longer and 'angled' version (B) will be used for both the ends of the greenhouse.

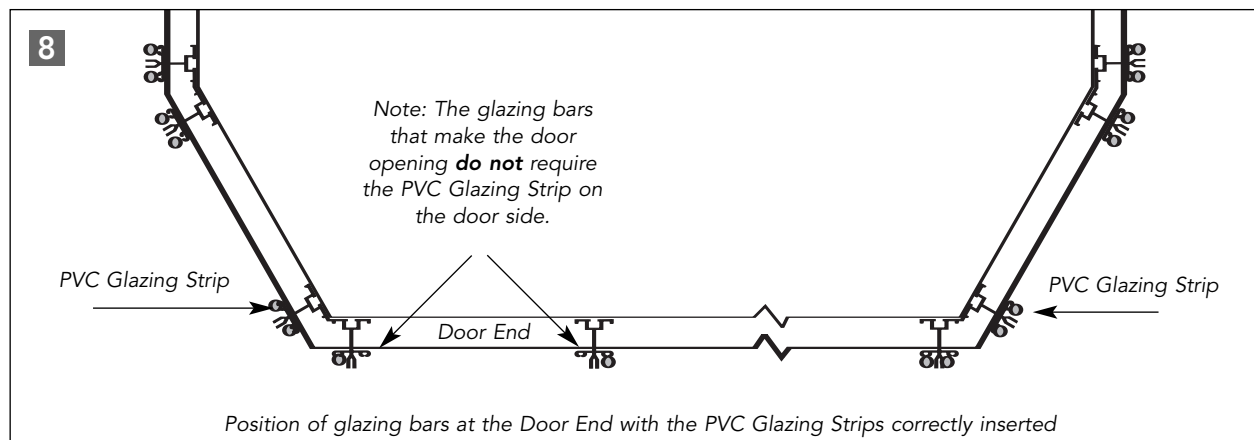

Position of glazing bars at the Door End with the PVC Glazing Strips correctly inserted

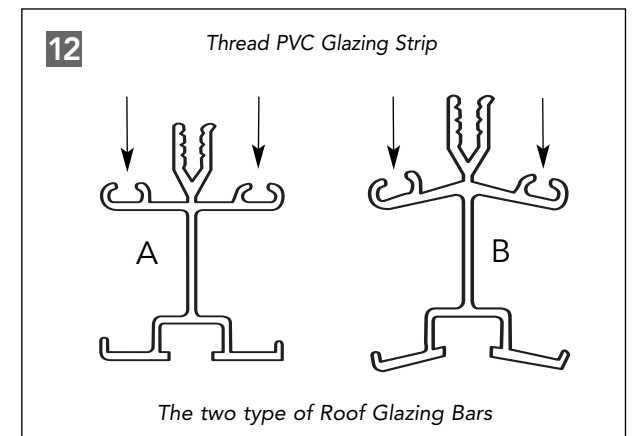

# RENAISSANCE ROOF ASSEMBLY

## ROOF ASSEMBLY

Locate the two Ridge brackets (13), Spacers and the Ridge Bar.

Position the two 22mm nuts and bolts into each end of the ridge bar along with the steel 'spacers'. Position the Ridge Bracket as shown in diagram 14, 15 and tighten.

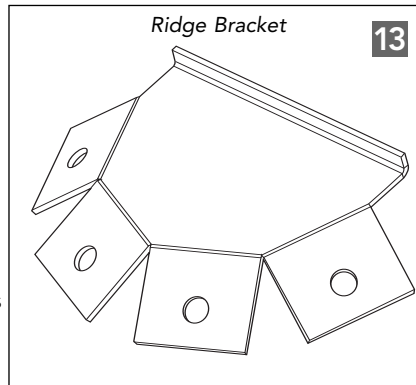

Note: Ensure there is room to fit the 'square' roofing glazing bar adjacent to the bracket. It may be worth offering up the bar and checking this before securing the nuts.

Repeat this operation at the other end.

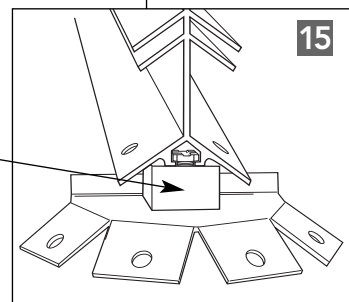
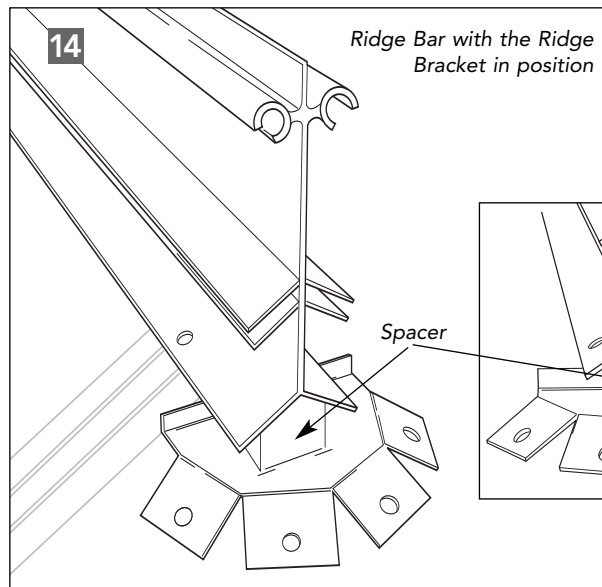

Double check that the Ridge brackets are square and secure.

Next, fix two of the longer 'angled' glazing bars to the centre two connections of the Ridge Bracket (A and B) with 10mm nuts and bolts, as shown below (16). Secure but allow for slight adjustments when fixing to frame. Do this at both ends.

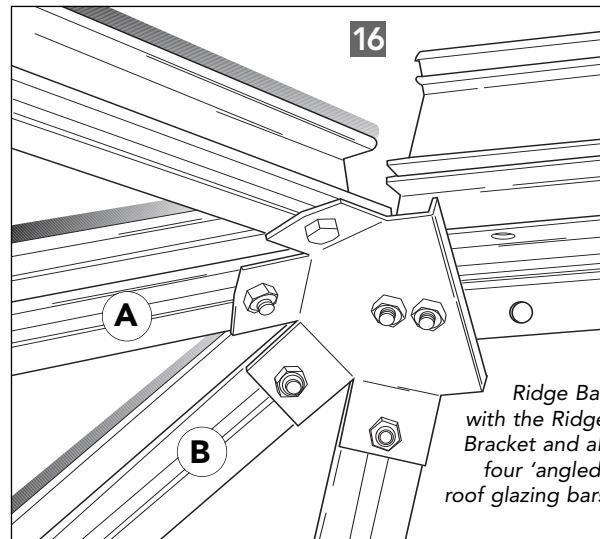

The next operation will ideally be done with two people. You may also need the use of a step ladder.

With support, manoeuvre the ridge bar assembly unit into position and secure into the correct place on both ends of the greenhouse with 10mm nuts and bolts. At this point check final positions and tighten the nuts, being careful not to overtighten.

The remaining roof glazing bars can now be fixed, it is advisable to complete the end sections first. Before securing the 'square' glazing bars (17), ensure the greenhouse is good and square.

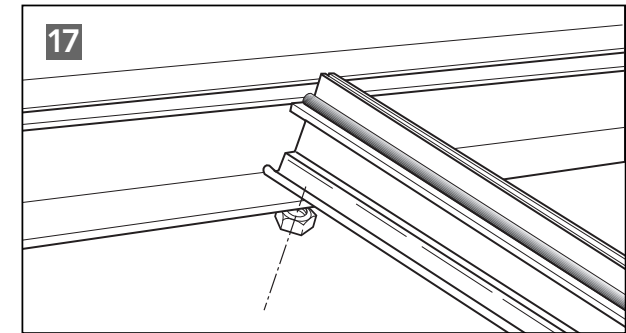

Also note, prior to fixing the 'square' glazing bars work out the position of any roof vents (number is dependant on model). A 10mm bolt will have to be slid in to each roofing bar which will support the vent. *Hint: use a piece of tape to temporarily hold these bolts in place.*

The greenhouse frame is now sturdy and self supporting and any support can be removed. But be aware that strong winds may cause the greenhouse to move as it has not yet been secured to its base.

## FINIALS AND CRESTING

Now the finials and ridge cresting need to be positioned and secured. Before starting it is worth measuring the ridge bar and then laying out the finials and cresting to create the desired effect.

One of the 'male' finials requires the tongue removing and the last cresting will have to be trimmed to get the correct finished length. Centre the crestings on the ridge bar and secure the finials in position with the supplied silicone.

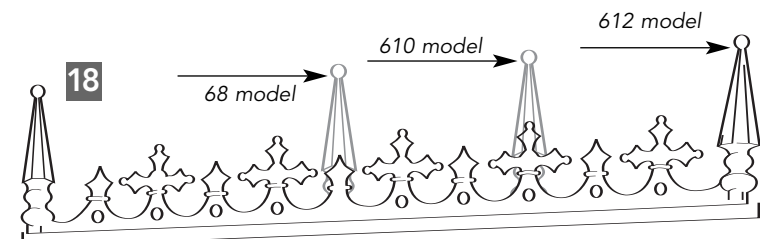



# RENAISSANCE - GLAZING THE SIDES

## PART ONE

It is advisable to glaze the four 'corner' section of the greenhouse as part one of the glazing. This is to ensure the stability of the building and help to keep the building square. Each of these glazing sections are complete units and will not effect future glazing work. Note: **DO NOT** complete the glazing of the greenhouse at this stage.

The four sections to start with are section 1,2,3 and 4. (please refer back the diagram on page five). This is assuming that the louvre vents are being fitted in the two 'end' sections of your greenhouse.

It is advisable to have these vents in the end panels, to create a healthy flow of fresh air. You can however, place them where it suits you needs. Do not site any vents in the panel next to the door(s).

Only take the glass pieces you require and keep the other the parts safe. Working with glass can be dangerous, care should be taken at all times and protective gloves should be worn.

Starting from one section, select a bar capping and secure with **ONLY** one self tapping screw at the bottom only.

Position the first 610 x 305 piece of glass, fitted with a 4mm separator strip, between the capping and the glazing bars. Next carefully place the large pane - 1628 x 610 - into the separator at a slight outward angle. The top of the glass can now be gently positioned under and into the gutter, in the same motion push the separator joint inwards until glass is in final position. Diagram 20.

Next, secure the glass panels by fastening all the self tapping screws in the corner capping bar/glazing bars. (Diagram 21) Secure the capping cover by clicking it into position at the top edge, then gently pressing, in a downward motion, push the cover in with the side of your hand. (Diagram 22). Continue fitting the other

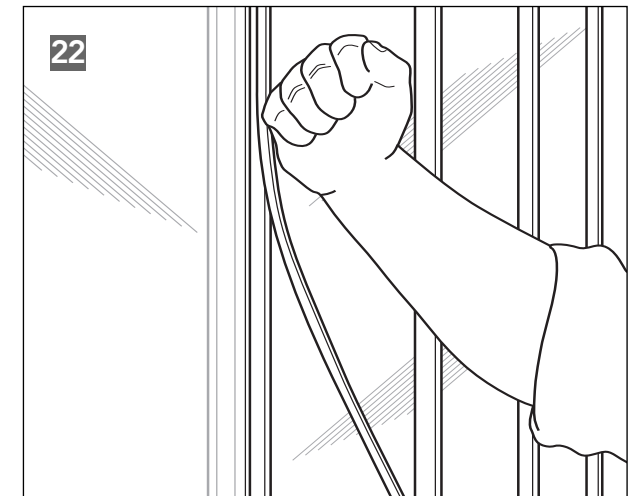
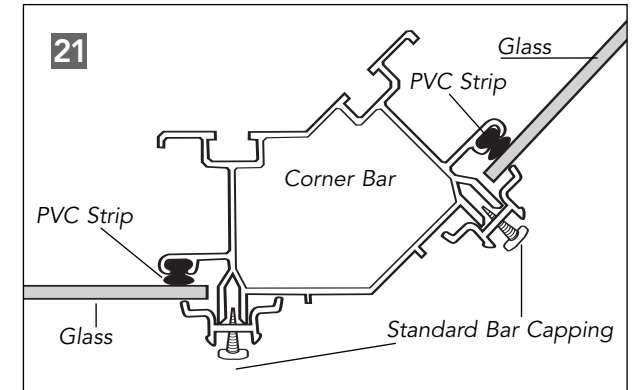
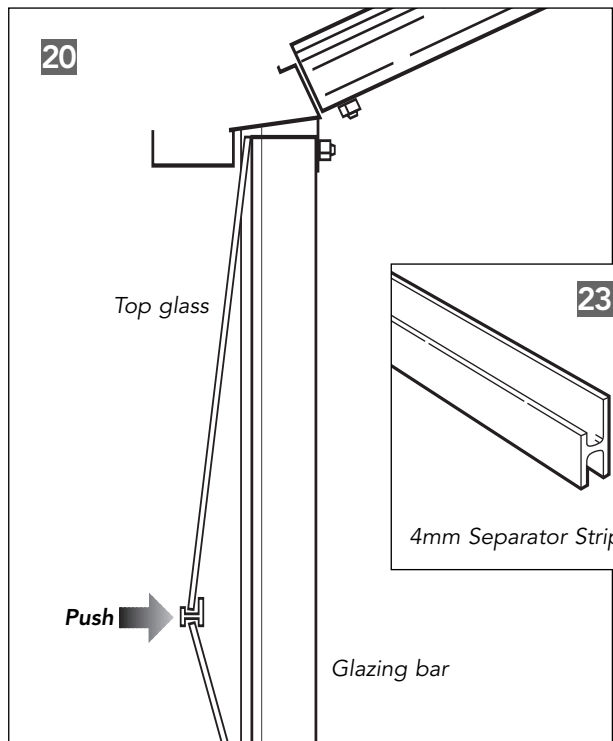
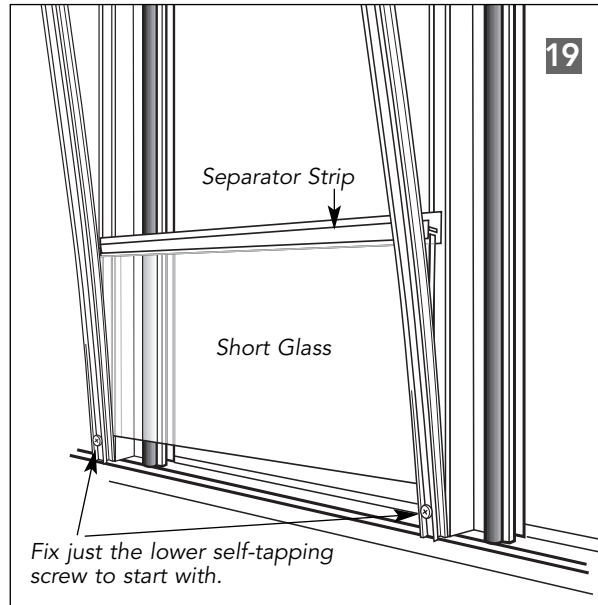

three 'corner' glass panels in this manner, securing the standard bar capping as you go.

At this point you need to assemble and fix the door threshold and door guide track before continuing with the glazing.

## FITTING THE DOOR TRACK

Locate the Inner Door Track, Outer Door Track and Centre Door Stop. (See diagram 23/24 on page 9). Using short bolts secure the stop to the track using the holes provided.



# RENAISSANCE - FITTING THE DOOR TRACK

**NOTE:** The stop is slightly off set and the off set should face up towards the single hole.

Fix the outer and inner tracks by clipping them together. Put a 10mm bolt in each of the holes near the ends. (See diagram 25).

Identify Hip Double Door Header, two Doorway Header Plates, and Door Header Bracket.

Fix the side of the door header with 3 holes in it to the door track with 10mm bolts (See diagram 26). Identify the two Door Track Brackets ("S" Shape) and hook one end into the top of the bar cap covers either side of the door. (See diagram 27).

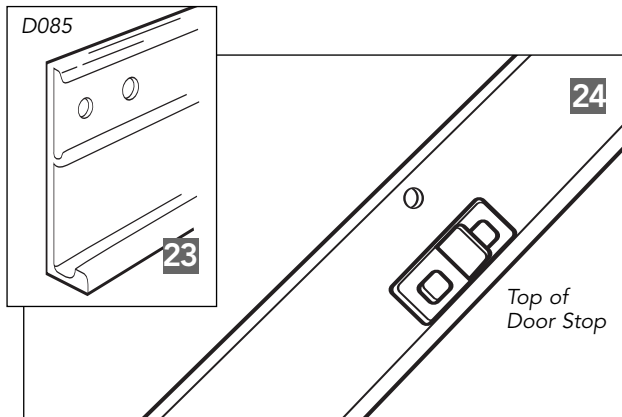

Fix the Door Header Bracket with a 10mm bolt in the hole in the gutter at the centre of the doorway.

Note the bracket is not symmetrical and fits as shown. (Diagram 28).

Now with someone helping you offer the assembled door track up in position and secure it to the bracket with a 10mm bolt.

Fix the doorway header plates, using a cropped head bolt in the glazing bar and two 10mm bolts in the other two holes. (See diagram 29).

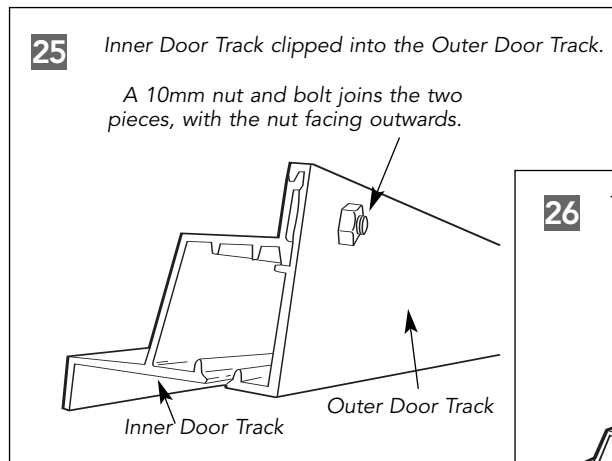

Ensure the underside of the track is sitting on the 'S' shaped brackets. Check everything is square and double check all bolts are done

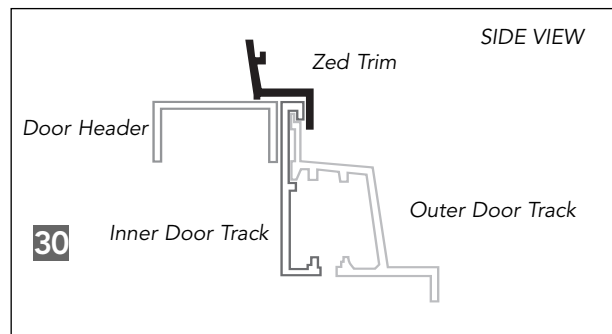
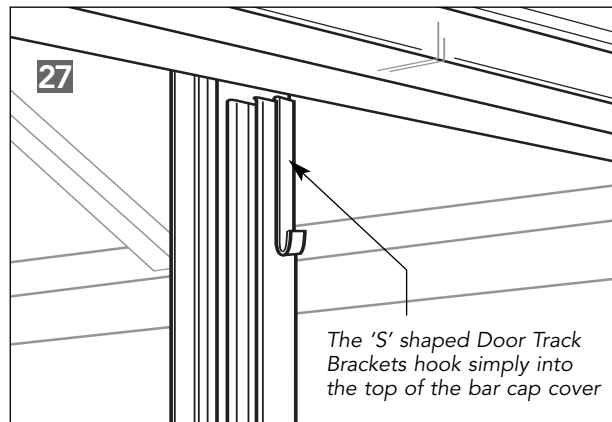

up tight. Screw through the holes of the door track with self tapping screws into the bar capping behind it. The plastic Z Trim can now be pushed into place. (See diagram 30).

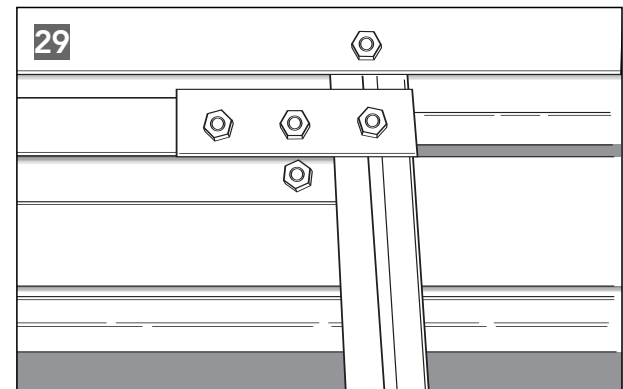
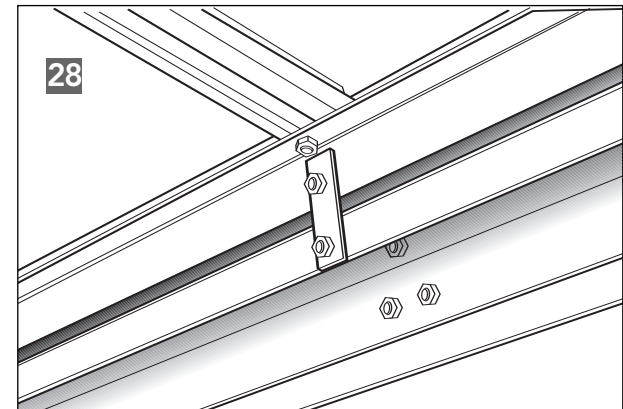
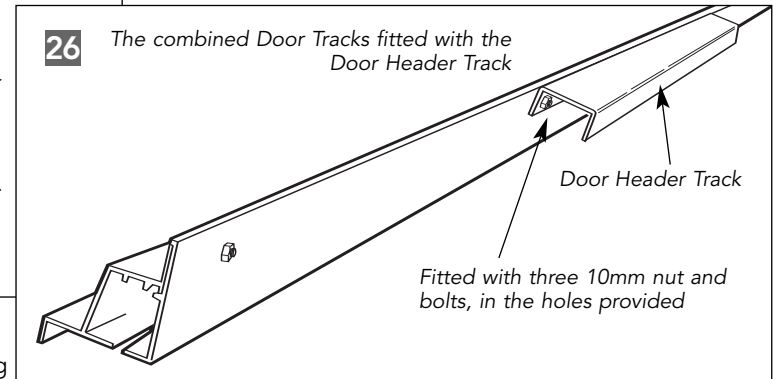

# RENAISSANCE

## DOOR GUIDE & THRESHOLD

From the door kit locate the door guide and the door threshold.

Position the Door Guide onto the Gable Base Rail to fit with an equal gap at either end. The door guide should 'sit in' comfortably onto the gable base rail groove. (Please refer to diagram 31).

Now fit the Door Threshold in the doorway, by placing the short angle end into the door guide. With downward pressure clip the threshold until it locks into position. (Please refer to diagram 31).

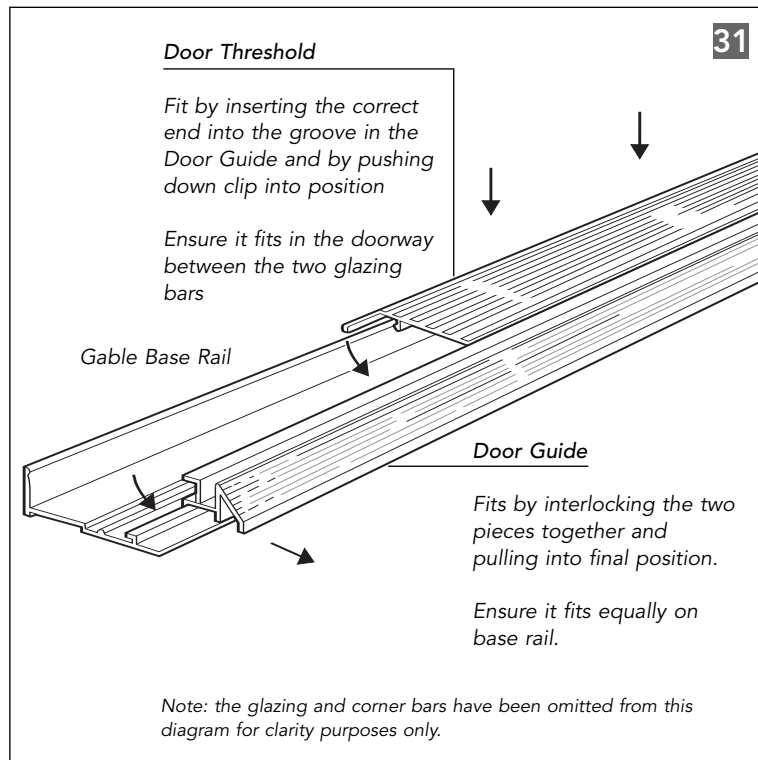

## GLAZING - PART TWO

The remaining side sections can now be glazed. Each section is completed as described on page 8.

## LOUVRE VENTS

The panels which are to contain the louvre vents can also be completed. See page 18 for full instruction on how to assemble the louvre vent.

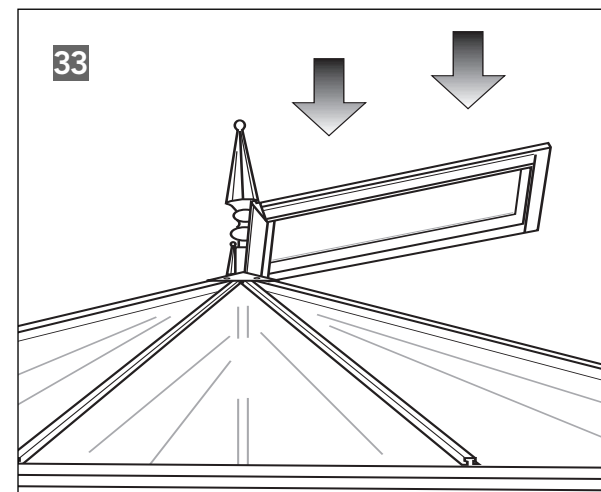
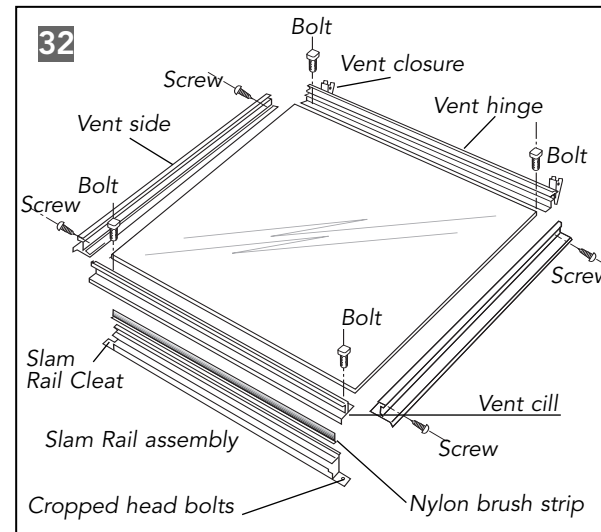

# RENAISSANCE - ROOF

## ROOF VENT

Identify the vent kits, fittings packs, two pieces of glass 550 x 450 mm and the boxes containing the automatic openers.

The slam rail first needs to have the nylon brush strip slid into the appropriate channel, protruding by approximately 5mm each end. Get two 15 mm bolts and nuts (from the supply of fittings in the Automatic Opener Box, not the Vent Smalls Pack) and temporarily fix them in the centre of the groove of the slam rail. These will be used later for fixing the openers. From the Smalls Pack slide a 10mm square headed bolt into each end the same groove and fix one end of the cleat to it. Fix a cropped head nut and bolt into the other hole in the cleat and put these and the openers out of the way for use later.

Now assemble the vent (see diagram 32). First fit the two side members to the vent hinge with 10mm bolts and slide the glass into position. Now fix the vent cill with 10mm bolts. Use the self-tapping screws to fix through the holes at each corner, not forgetting to fix the vent hinge closures at the same time.

Check the vent is square, all fixings tight, and then run a bead of silicone (supplied), on the outside, around the perimeter of the glass and the edge of the frame to seal any gaps.

Loosely fit the screws into the Vent Hinge Stops, and being careful not to lose them, put these and the vents to one side for later use.

# RENAISSANCE - ROOF

## GLAZING THE ROOF

Each section comes as a single piece of glass. Great care should be taken when handling glass and it is recommended that suitable gloves should be worn.

**NOTE:** Before glazing it is advisable to separate the various bar caps (34) and covers (35), required for the roof plus the self-tapping screws.

The starting point should be the most convenient but it is recommended that you start with one of the triangular pieces of glass and then work around the greenhouse in one direction. We suggest right handers work in a clockwise direction and left handers anticlockwise.

## FIXING THE FIRST ROOF VENT

Fix the vent slam rail in position above the small piece of glass already fitted. From inside the greenhouse slide the cropped head bolts into the grooves of the

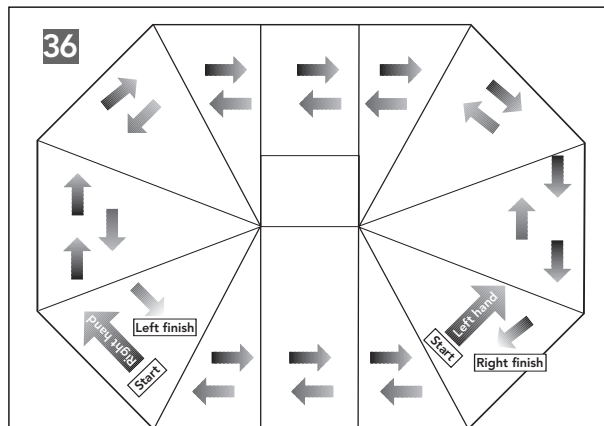

*This is an example of how to proceed with the glazing of your greenhouse. Right hand clockwise, left hand anti-clockwise.*

*The sample shown is a 68 model, use the same principle on the 610 and 612 models.*

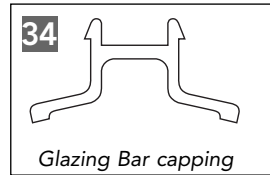

Glazing Bar capping

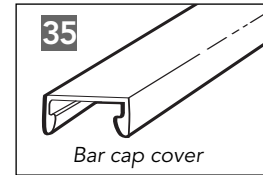

Bar cap cover

glazing bars either side of the vent opening and slide rail down onto the edge of the glass to ensure a good tight fit before tightening the nuts to secure.

Next the roof vent and vent stops need to be fitted by sliding them into the groove provided in the ridge (see diagram 33). A vent stop goes either side of the vent and when the vent is centrally positioned over the aperture the screws on the stops should be tightened to stop the vent moving sideways.

## GUTTER JOINTS

Where each angled gutter section meets a 'joiner' (diagram 37) needs to be placed to make a water tight system.

The fitting of these gutter joints can be hard work and will require some exertion to put into place.

**The wearing of protective gloves is essential.**

Use a set of steps that are being supported as some exertion is needed by the person inserting the bracket

The knack of fitting is to insert the upstand on the bracket nearest the outside of the building first. Then push the back of the bracket down and locate the two rear upstands under the lip in the gutter profile. (Diagram 38)

Finally apply a bead of silicone in/on joints that are left uncovered by the bracket

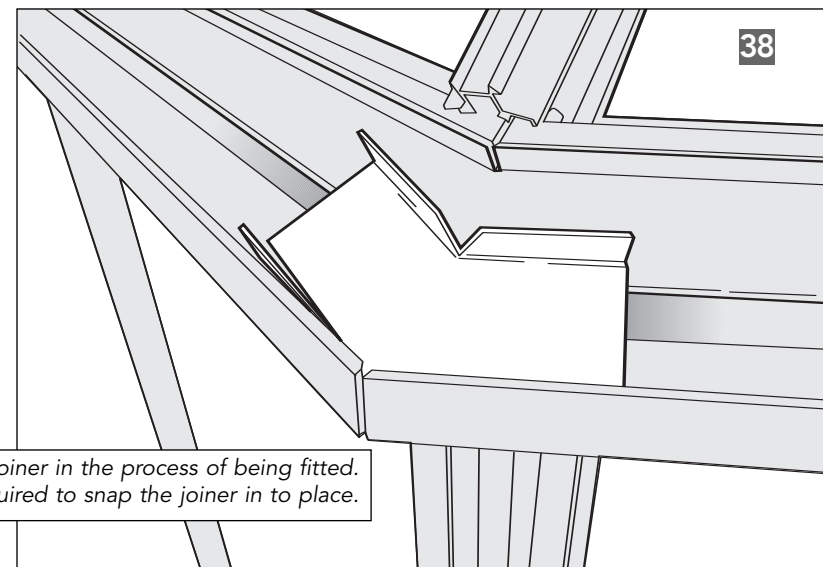
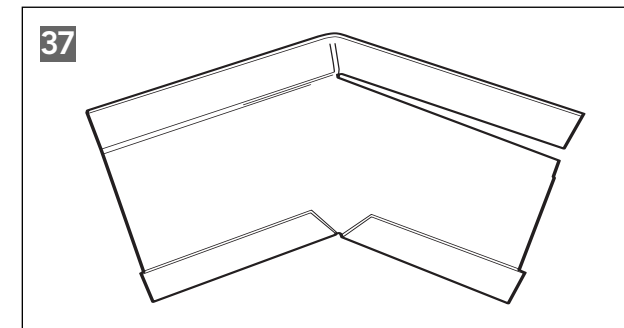

*This diagram shows the gutter joiner in the process of being fitted. Downward pressure is required to snap the joiner in to place.*

# RENAISSANCE - FITTING THE DOOR

## ASSEMBLY OF DOUBLE DOORS

Suitable for the 612 model

From the box labelled 'Door' locate the four Door Stiles, two plain plus one with lock pre-fitted and one with lock strike plate pre-fitted. REMOVE the key, attached to the stile, with the lock and keep safe. Also find the two Door Cross Bars, Door Bottom Bars and Door Top Assemblies, with pre-fitted rollers, plus the Smalls Pack.

Lay the parts out on a suitable flat surface as if viewed from inside the greenhouse. (See diagram 40). Loosely fix the Door Cross Bar that goes in the middle of the door with Pan Head Bolts and nuts.

Note: Cross Bar fits with the glass recess facing down.

Locate the glass to go in the bottom section of the door (922 x 555mm) and the PVC Edge Strips (905mm long). Refer to diagram 39 - and fit the PVC Edge Strips onto the glass, allowing an even amount of glass to stick out at each end.

Now slide the edging strips into the grooves in the Door Stiles so the end of the glass fits into the recess of the Middle Cross Bar. Now fix the Bottom Door Cross Bar with Pan Head Bolts.

Fit the appropriate PVC Edge Strips to the piece of glass that goes in the top part of the door, again with an even amount of glass exposed at the top and bottom. Locate the PVC Edge Strips in the grooves of the Stiles and slide the glass into place. Now fix the Top Door Bar.

Check the pan head bolts are finger tight and lift the door onto its side and screw door stiles to the cross bars through the holes provided using self-tapping screws.

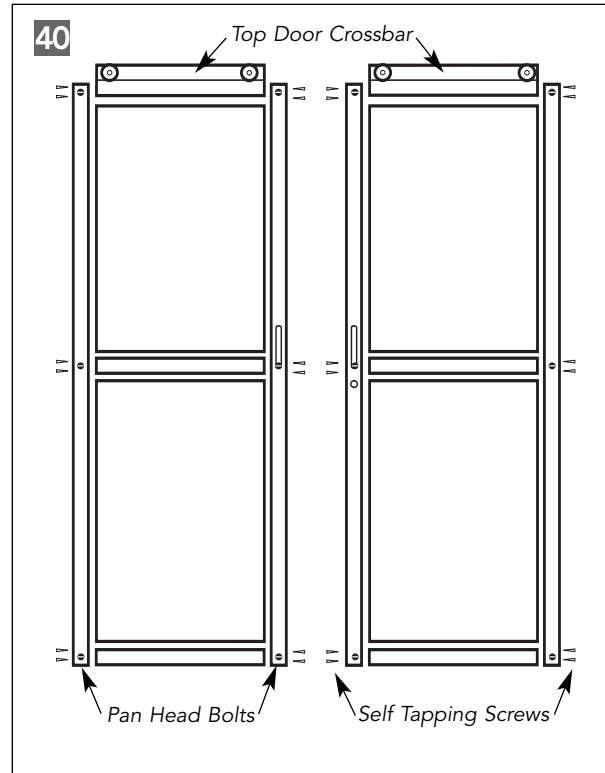
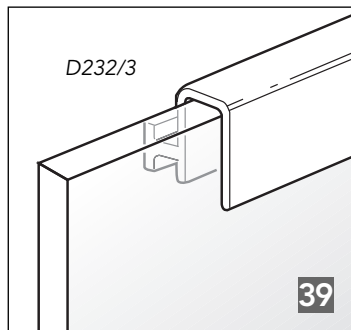

Fix the Door Handle through the pre-drilled holes after loosening off one of the bolts already occupying the lower hole. Now tighten up all the bolts. (41)

Repeat this procedure to complete

the other door.

Fix the Nylon Door Guides centrally on the Bottom Cross Bar. Slide the Nylon Brush Strip

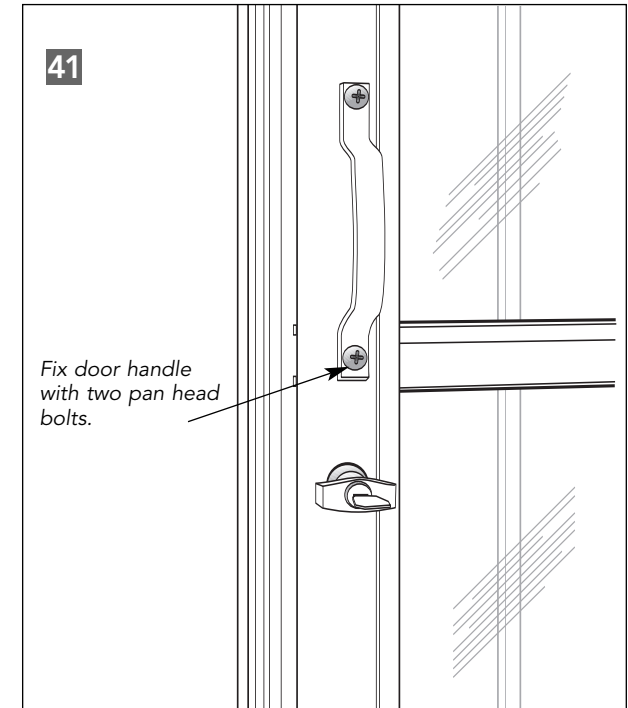
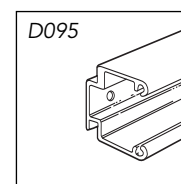
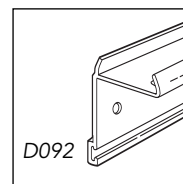
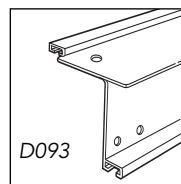
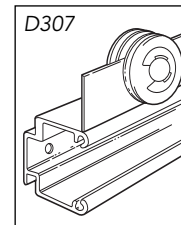
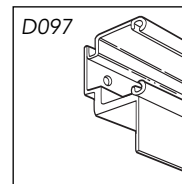

into the groove on the Door Style and cut to length. Crimp the bottom of the groove to prevent it slipping out. These will seal against the door posts when the doors are closed.

## SINGLE DOOR ASSEMBLY

Suitable for the 68 and 610 models

To assemble the single door is based on the same instructions for the double door. The lock and handle will be on the left hand side, with a door stop on the corner glazing bar to the left side of the door. (42)

The door will slide to the right.

# RENAISSANCE - FITTING THE DOOR

## FITTING THE DOOR

Slide door wheels into the top track, at the same time ensuring the nylon door glide engages in the door guide. Diagrams 43 and 44.

Slide on completely and repeat process for other door.

Check that both doors run freely, if not then check that the outer track is sitting squarely on the inner track.

Check that door track is parallel to door guide.

When the doors are running to your satisfaction, fit a rubber door stop (45) to each end of the track in the holes provided using M4 x 10mm stainless steel nut, bolt and washer.

Finally push the two plastic door track covers onto the ends of the door tracks. (46)

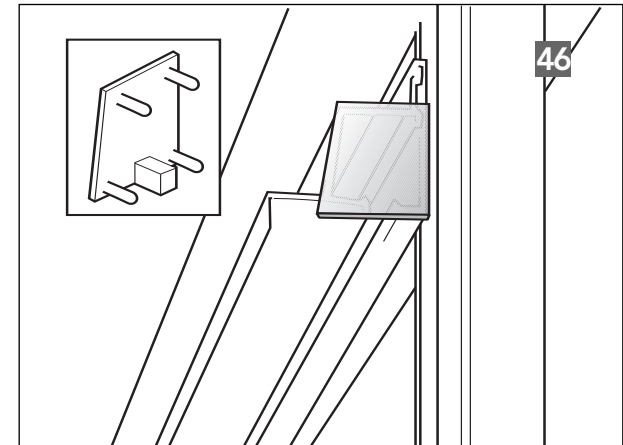

## SEALING THE RIDGE ENDS & FIXING THE RIDGE CAPS

You need to silicone the small gaps between the ends of the ridge glazing bars and end of the ridge. Then fit the ridge cap. (See diagram 47). Before fitting with two self-tapping screws through into the bar cap cover, **ensure the pointed end of the cap is tight up against the end of the ridge.**

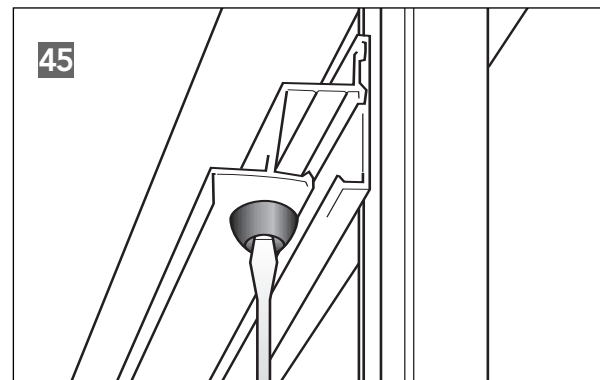
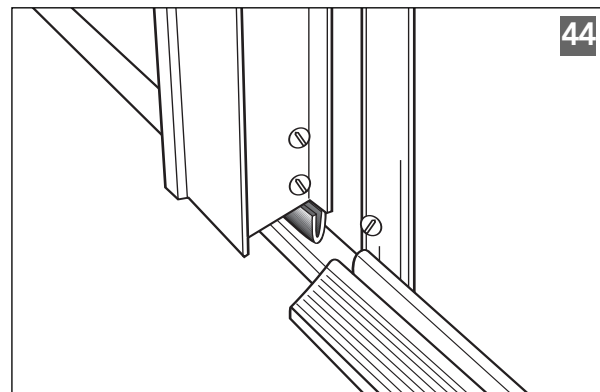
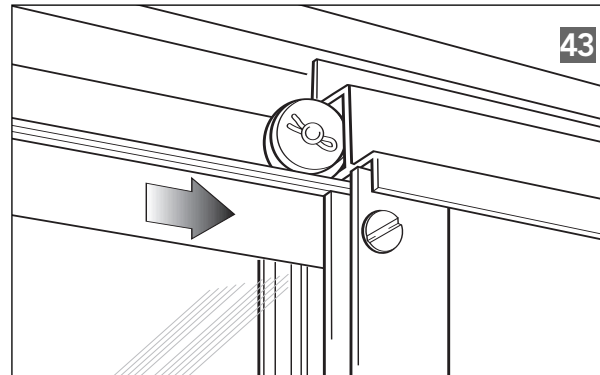
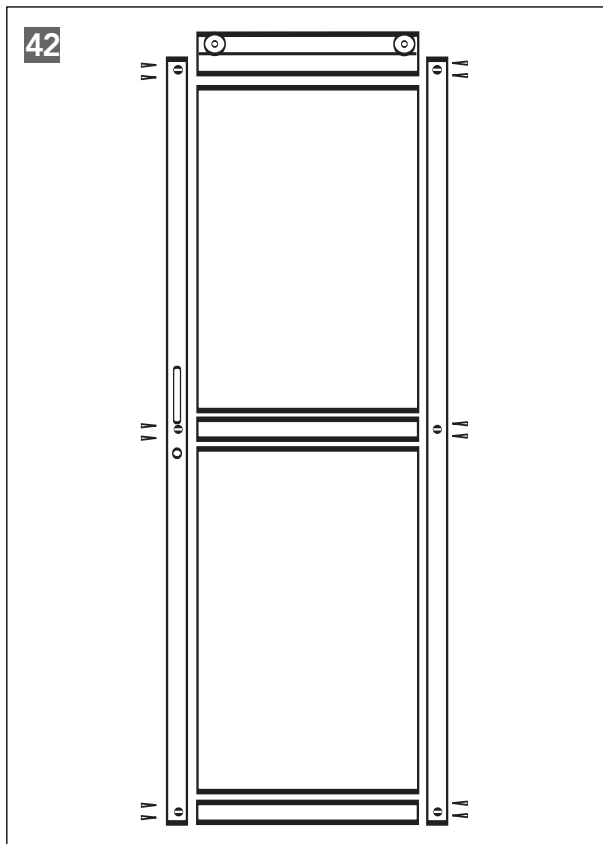
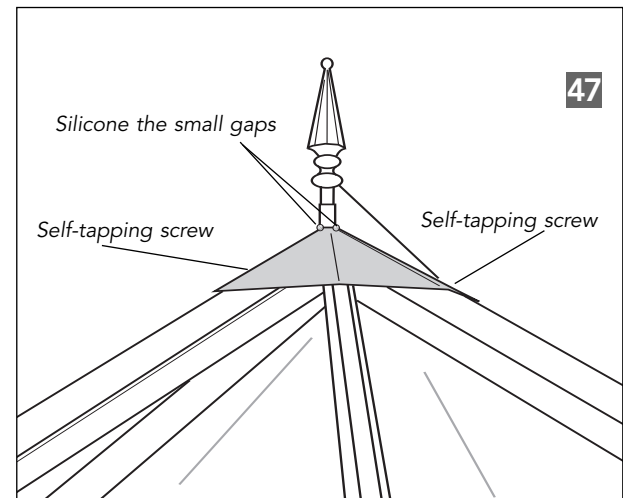

## RENAISSANCE - FINISHING TOUCHES

### FITTING THE AUTOMATIC OPENERS

Remove the opener/s from their box and follow the manufacturer's instructions.

### BASE BRACKETS

When the greenhouse is in its final position, check that it is square, diagonals are equal and the base rail overhangs evenly all around.

Drill through hole in bracket with a 7mm masonry drill to a depth of 50mm.

Insert a rawlplug and secure the bracket with the supplied 2" woodscrew. (See diagram 48).

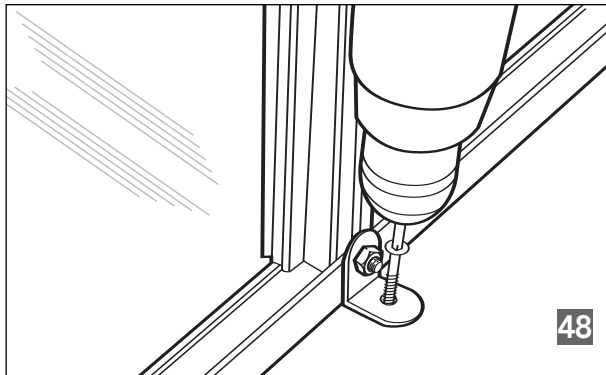

### NOW FIT THE STAGING AND/OR SHELVING

Follow the relevant instructions on pages 19 and 20.

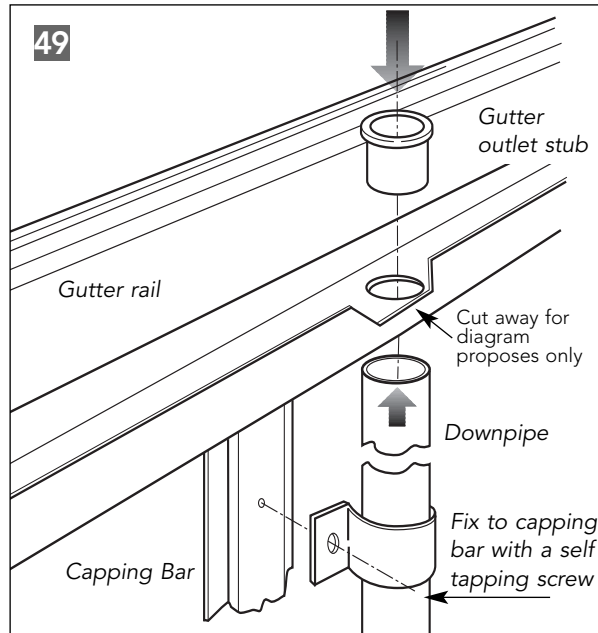

### DOWN PIPE

Fit the gutter outlet stub in the drainage hole, located in the centre of the back gutter.

Fit the angled rain water pipe outlet onto the end of the down pipe and push the other end onto the gutter stub (see diagram 49). Finish by drilling a small hole through the bar capping and using a self tapping screw to fix the pipe bracket at the appropriate height.

### NUT COVERS + BADGE

The greenhouse is all but complete, with just two jobs left to do. Go all round the building and fit the covers over every nut that is visible in order to produce a tidier finish. Finally fix the name badge centrally above the doors.

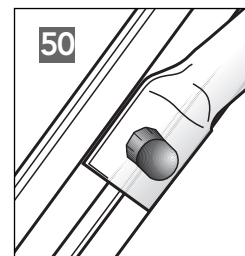

**Robinsons**  
Premier Aluminium  
**GREENHOUSES**

*Congratulations, a job well done and thank you for purchasing a Robinsons Greenhouse, which we hope, will give you many years of gardening pleasure.*



Measurements in mm.

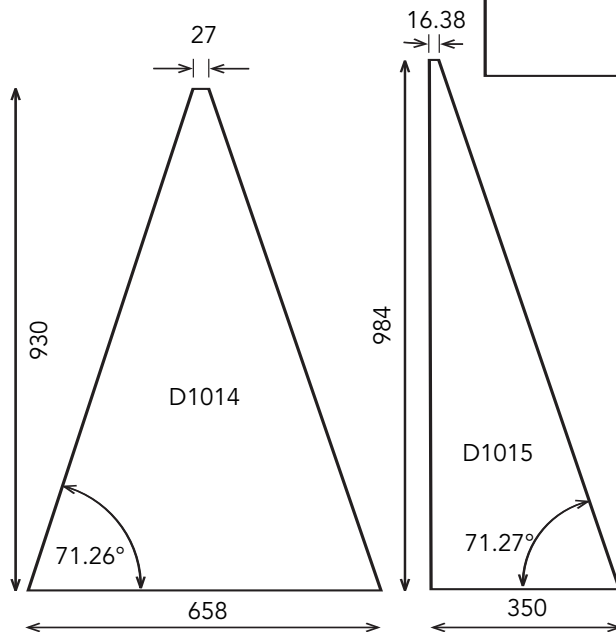
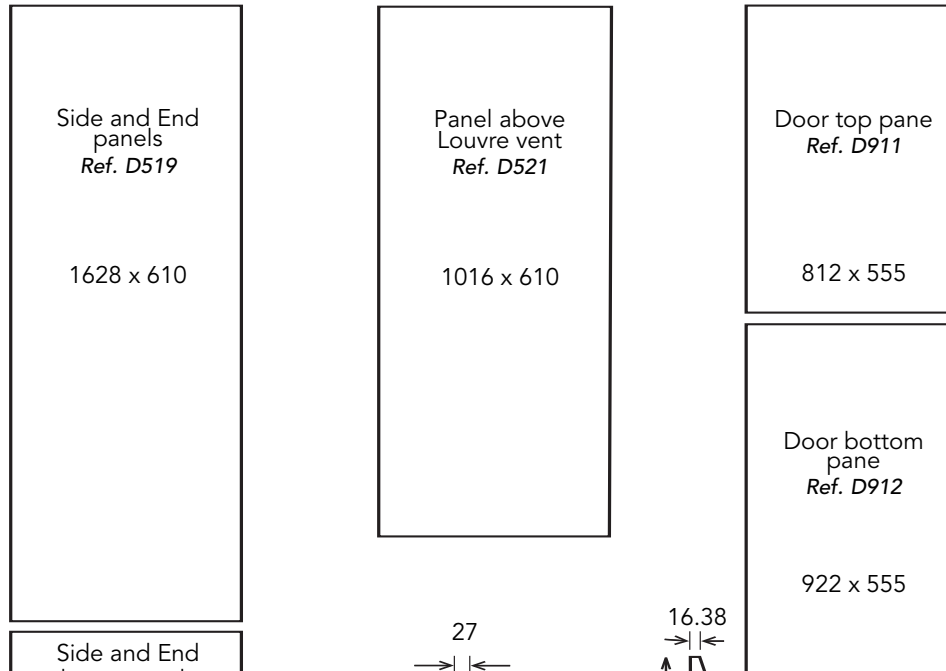

These sizes and reference numbers are common to both the 10' and 12' models.

The 10' and 12' roof glazing plans are on the next pages.

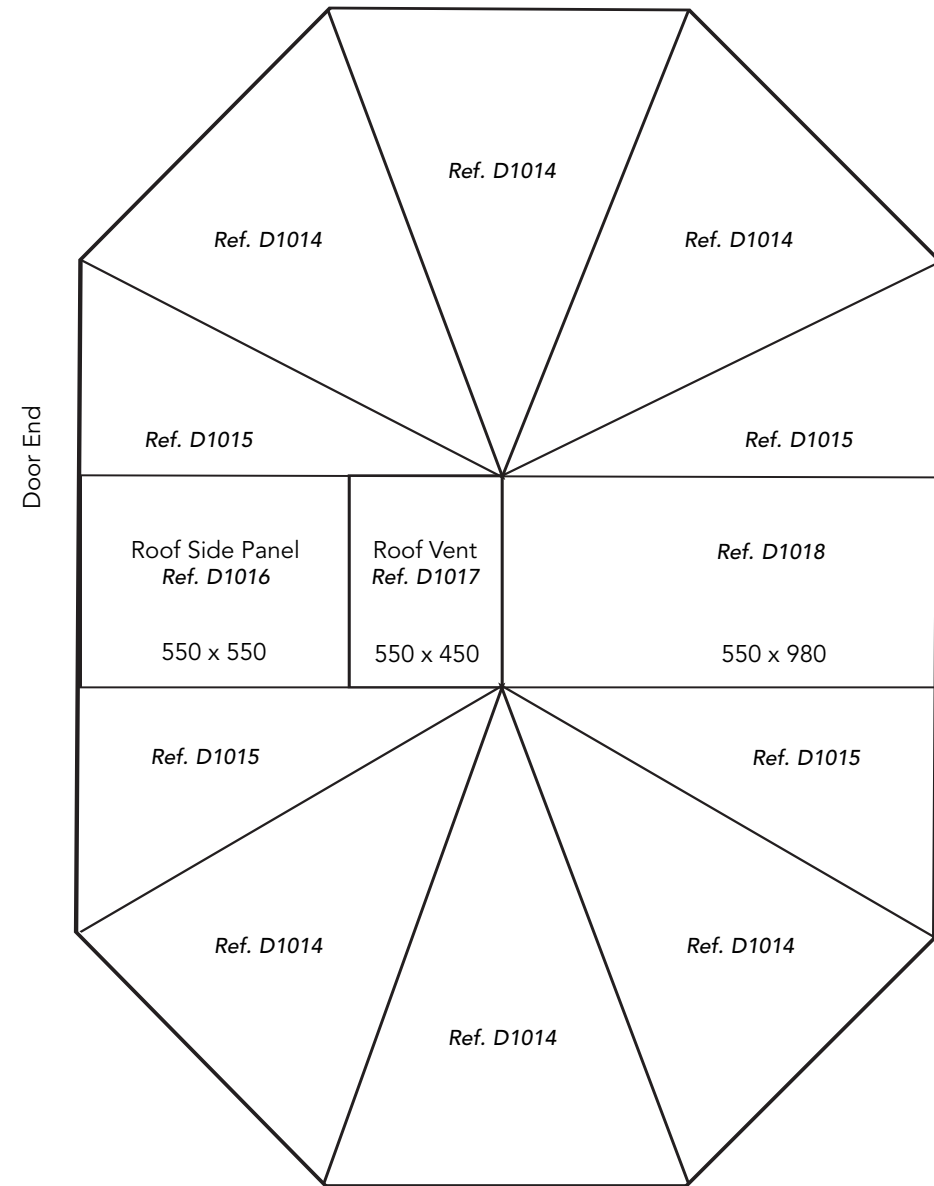

Measurements in mm.

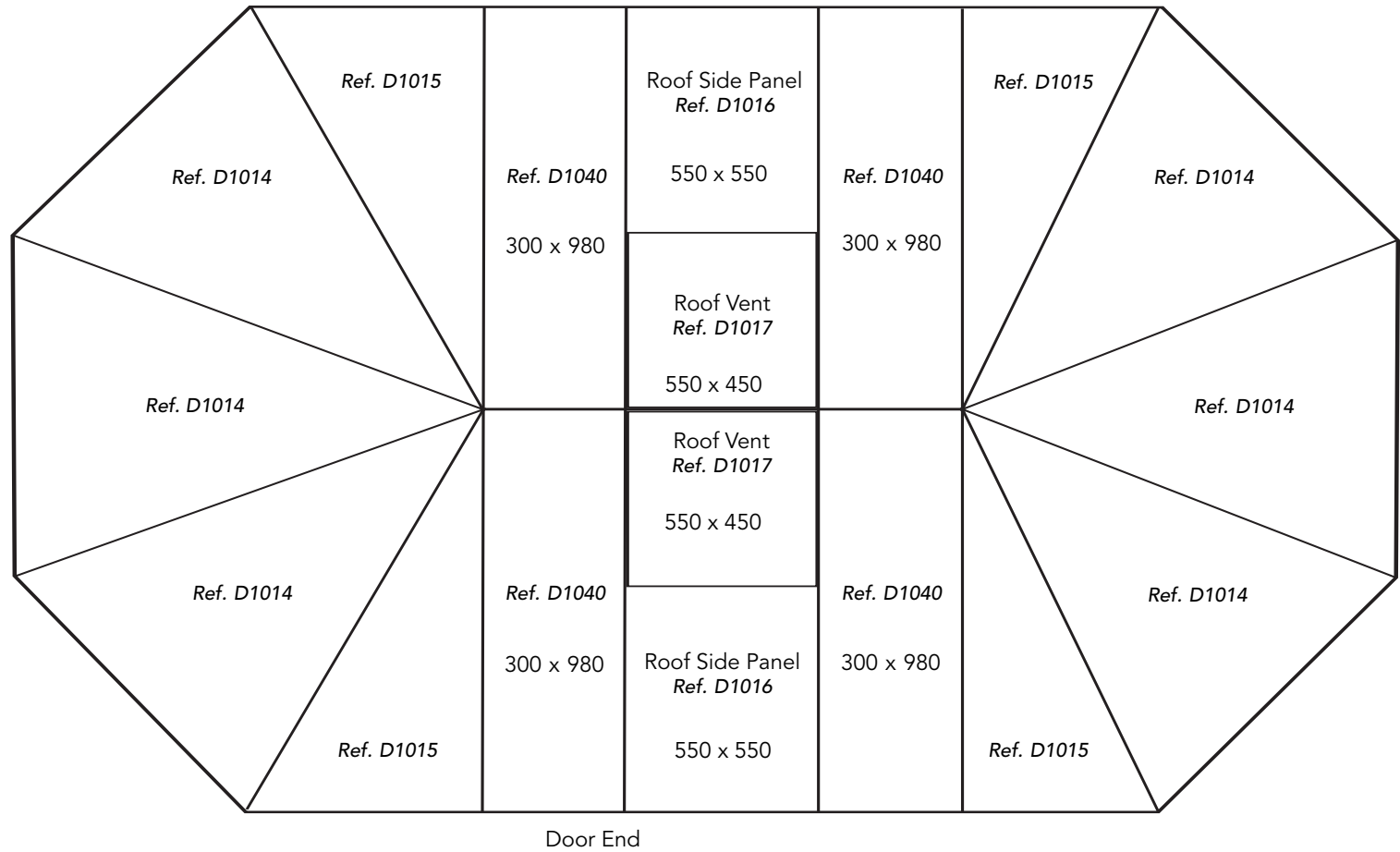

# RENAISSANCE - GLAZING PLANS - 4mm TOUGHENED GLASS ONLY

# 612 MODEL

Measurements in mm.

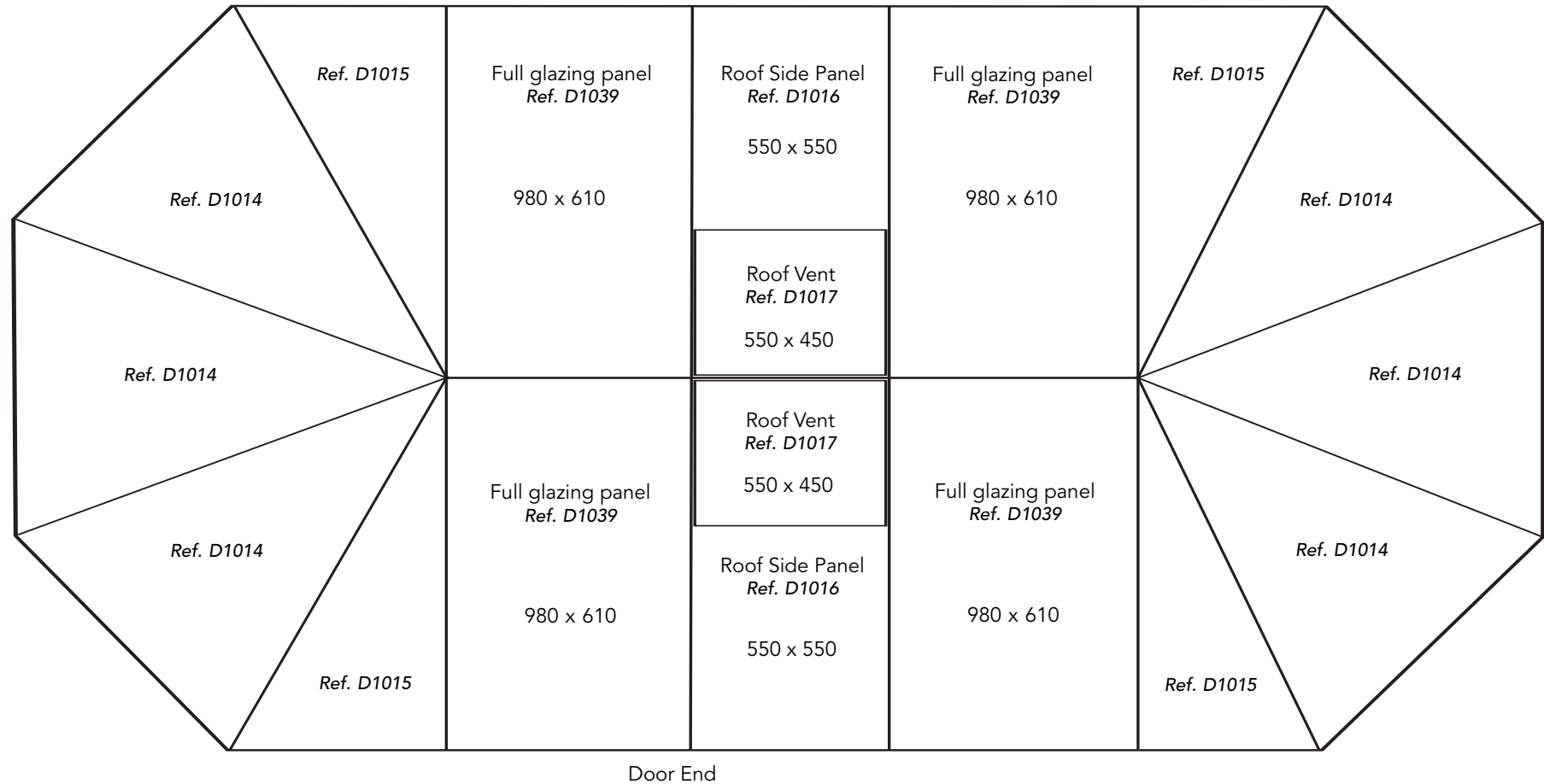

# RENAISSANCE - Louvre Installation Instructions

## D361 Louvre Kit

### INSTALLATION

- 1 Screw self-tapping screws through holes in the top and bottom cill members into the 'C' groove of the side jambs to form a complete frame.
- 2 From outside the greenhouse, fit the frame in place, fixing into position using the plastic bar caps and screws.
- 3 Open the louvre and slide glass blades into position from inside the greenhouse. To avoid excessive movement of glass, bend the retaining clips so that the louvre blade is firmly gripped.

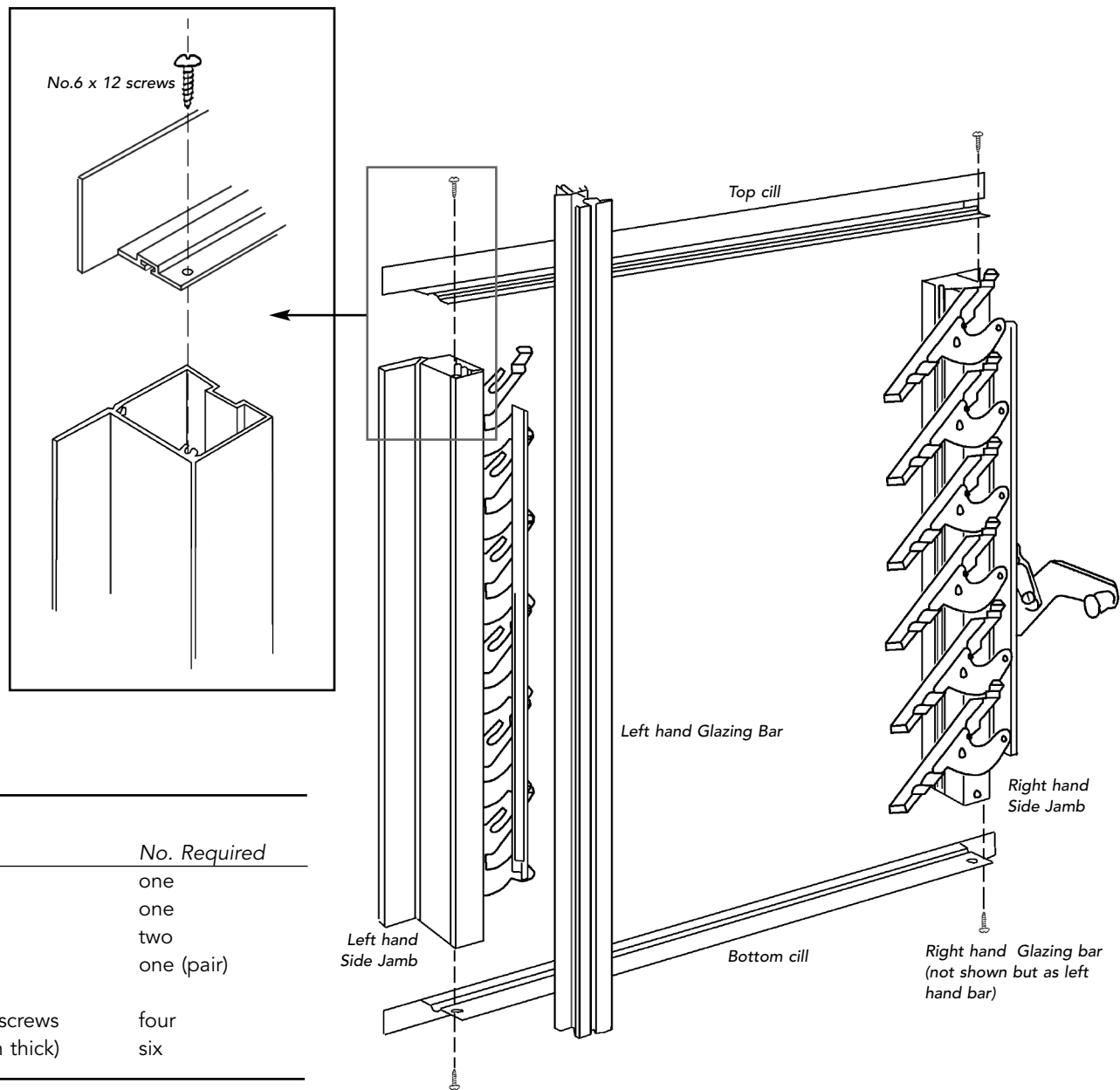

### CONTENTS OF KIT

Part No.	Description	No. Required
-	Instructions	one
D168	Louvre jamb set	one
D166	Louvre side member	two
D165	Louvre top/bottom (rubber fitted)	one (pair)
D362	Louvre smalls pack consisting of:	
	FS 6013 N0.6 x 12 self-tapping screws	four
D729 T/G	Louvre glass - 100 x 525mm (4mm thick)	six

# RENAISSANCE - SIDE AND REAR PRE-ASSEMBLED HIGH SHELVING

## 3-Slat - shelving

Fix the tubular brace (B) to aluminium greenhouse glazing bars, using cropped-head bolts. (The height of the shelving can be adjusted to suit individual needs). Ensure the bolts are correctly engaged in the nut groove before tightening. Next fix the short 90°

brackets (A) in a similar manner ensuring the brackets are level. Minor adjustments can be made to the bracket once the shelf is fitted, by loosening the nut slightly and moving the bracket up or down. A spirit level placed on the shelf will ensure it is level.

The shelf is fixed into its final position by the use of three wood screws. (See diagram 51).

Diagram 52 shows where the braces and brackets are placed and the remaining shelves fit together.

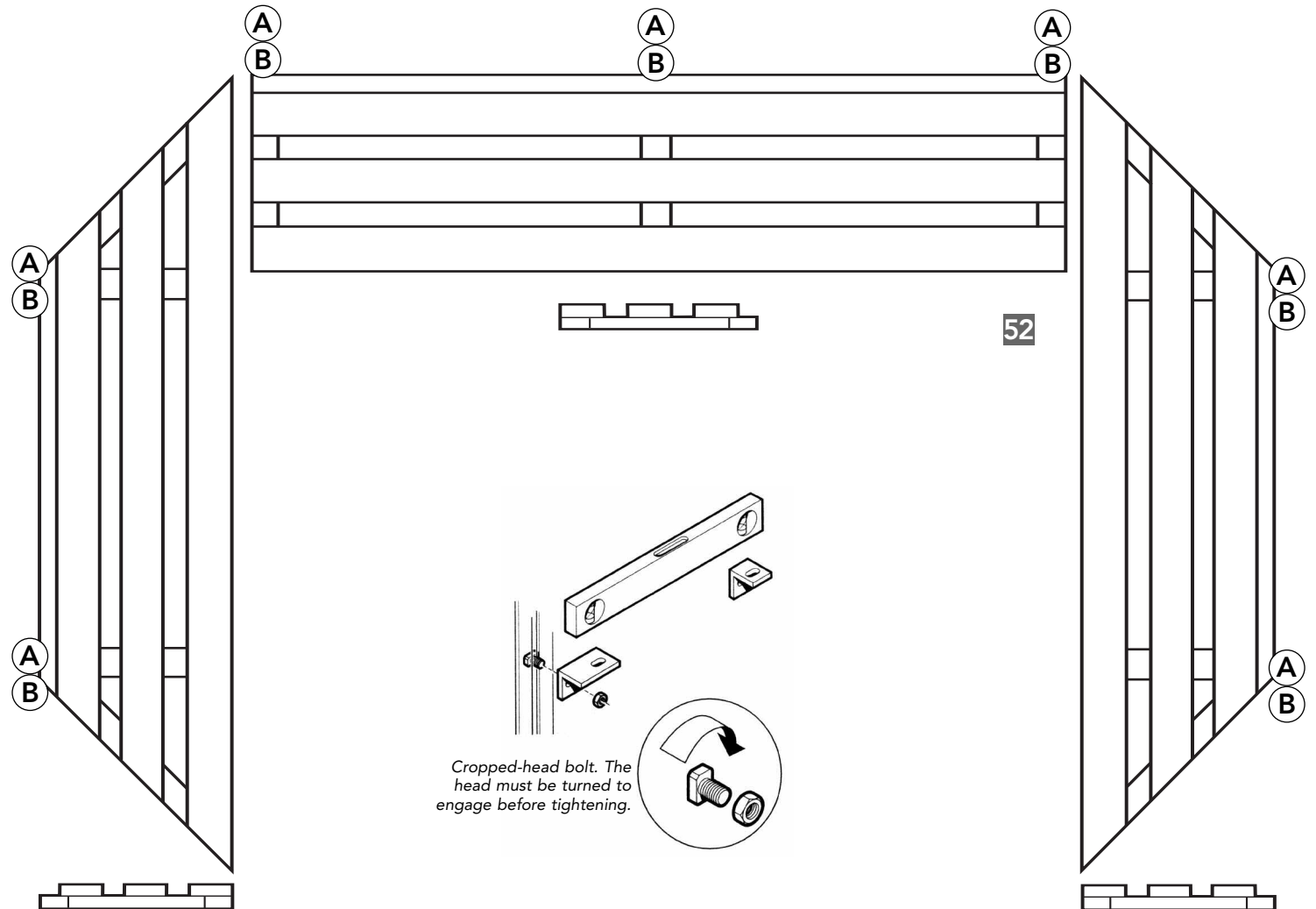
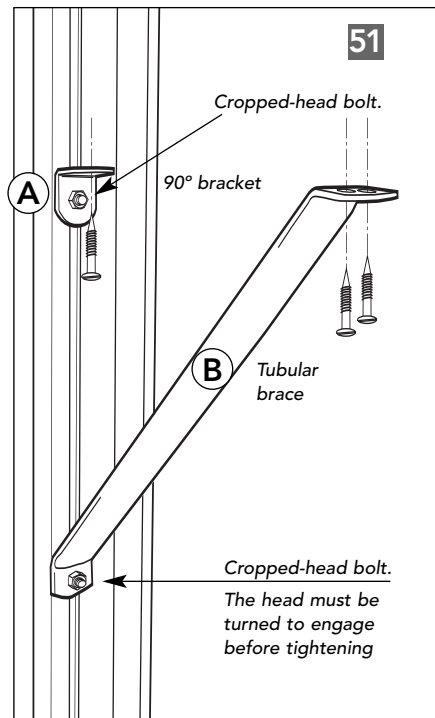

# RENAISSANCE - SIDE AND REAR PRE-ASSEMBLED STAGING

## 5-Slat - staging

In a similar manner to the high level shelving fix the tubular brace (B) to aluminium greenhouse glazing bars, using cropped-head bolts. (The height of the staging can be adjusted to suit individual needs).

Ensure the bolts are correctly engaged in the nut groove before tightening. Next fix the short 90° brackets (A) in a similar manner ensuring the brackets are level. Minor adjustments can be made to the

bracket once the staging is fitted, by loosening the nut slightly and moving the bracket up or down. A spirit level placed on the stage will ensure it is level.

The staging can now be fixed into its final position by the using of the wood screws. (See diagram 51, page 19)

The diagram shows where the braces and brackets are place and the remaining staging fit together. Note that the (A1) brackets (same bracket as A) are used to support the staging but are not connected to the greenhouse frame.

See diagrams 53 + 54.

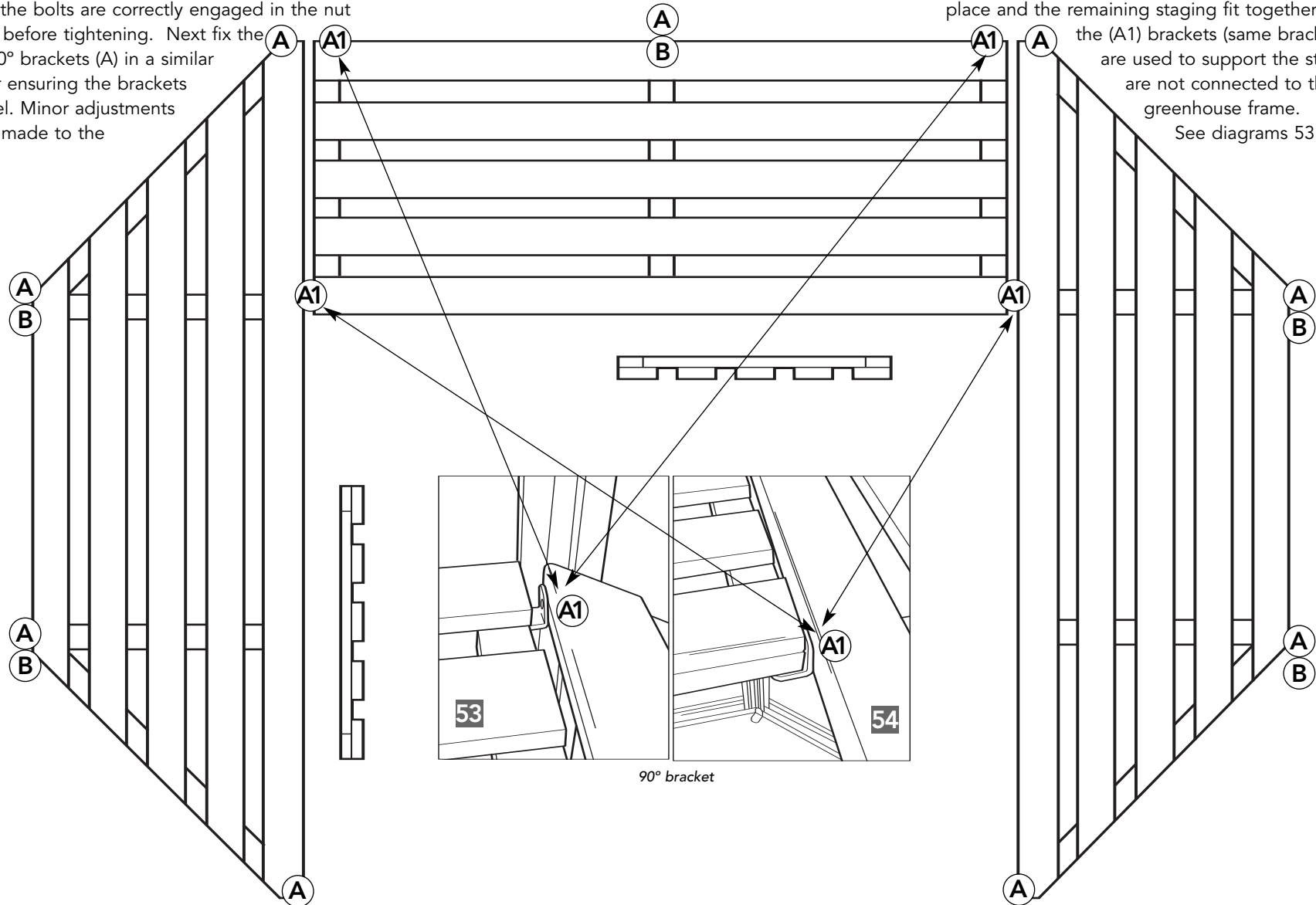



# RENAISSANCE - PARTS LIST

Ridge member



Glazing bar

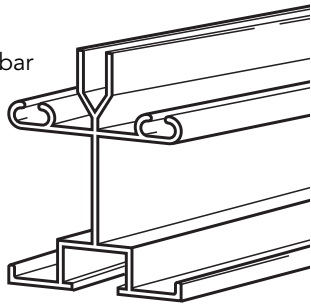

Glazing bar 'Angled'

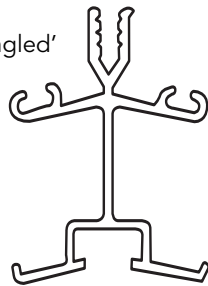

Hip gutter

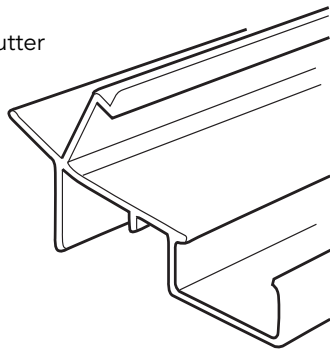

Corner glazing bar

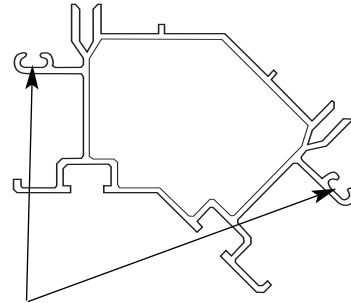

inside grooves with the PVC glazing strip in place



15mm Bolt + Nut  
bolt F5003  
nut F5006

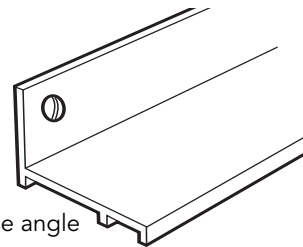

Base angle

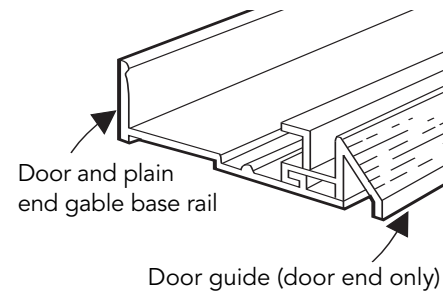

Door and plain end gable base rail

Door guide (door end only)

PVC glazing strip D231

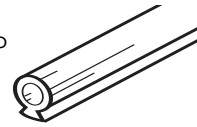

10mm Bolt + Nut  
bolt F5002  
nut F5006

Bar capping

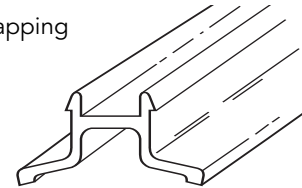

Bar cap cover

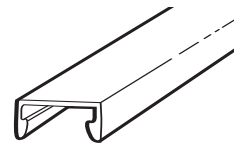

Door post capping

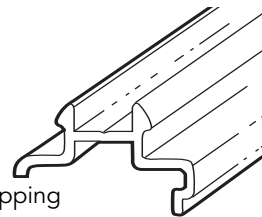

Standard bar capping

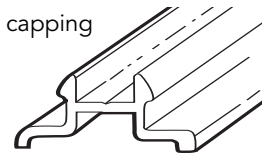

No 8 x 12mm self tapping Pozidrive screws FS6017



Vent hinge

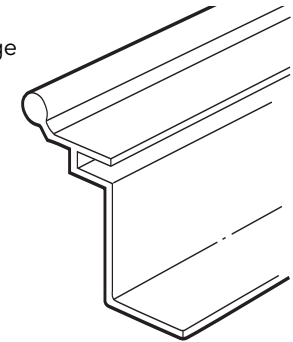

Vent side

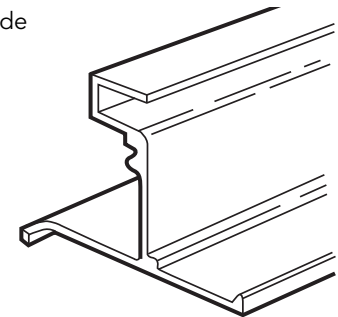

Vent cill

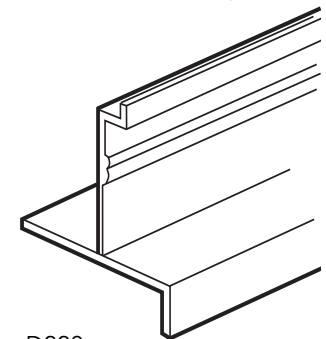

Vent stop D220  
Screw FS6060



Slam rail cleat D114

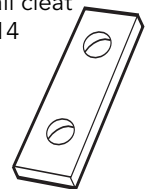

# RENAISSANCE - PARTS LIST

Vent closure  
D205R

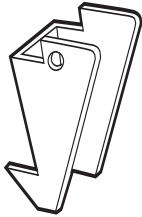

Cropped head bolts

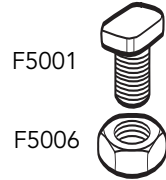

Separator Strip 4mm  
D101

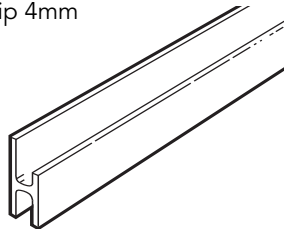

Door Track 'S' Clip  
D845

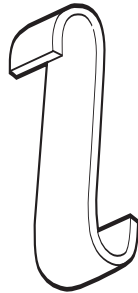

Centre door stop D150

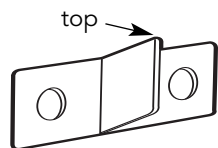

Inner door track  
D548

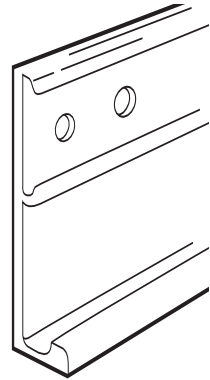

Outer Door Track  
D549

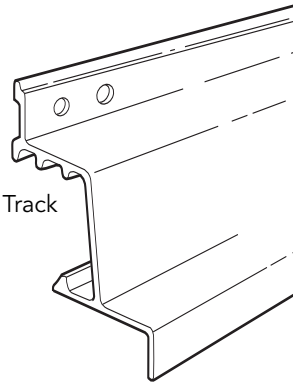

Doorway Header  
D512

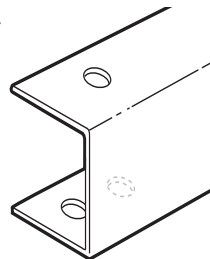

Door Header Bracket  
D552

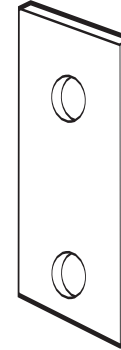

Doorway header plate  
D163

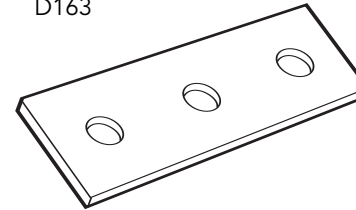

Zed trim D223  
Double door

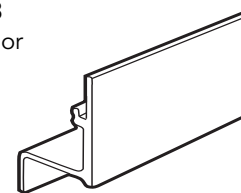

Door side member (outer)  
D093 LH  
D094 RH

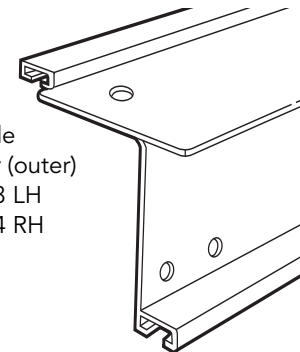

Door side member (inner)  
D092

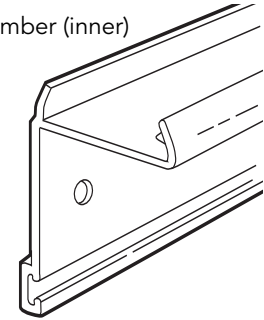

Bottom door crossbar D097

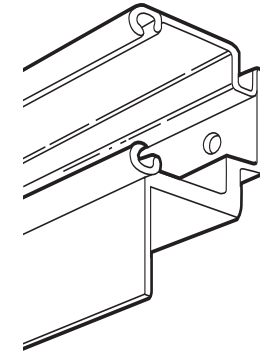

Door crossbar  
D095

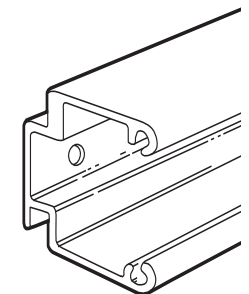

# RENAISSANCE - PARTS LIST

Ridge Cap  
D1023

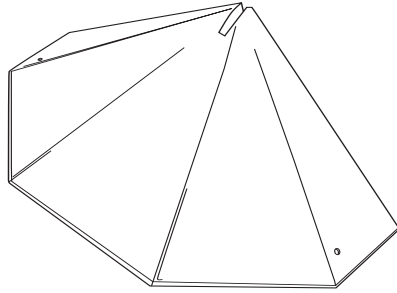

Gutter joiner  
D1024

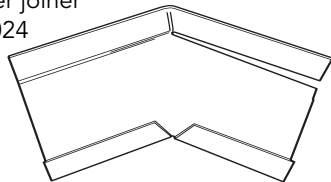

Rainwater pipe outlet  
D207

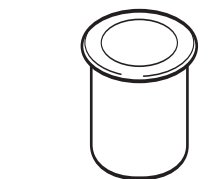
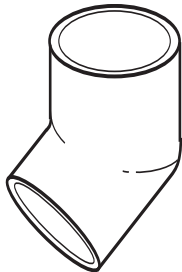

Gutter outlet stub  
D201

M6 x 10mm pan head bolts  
D263



PVC edging strip  
D232 & D233

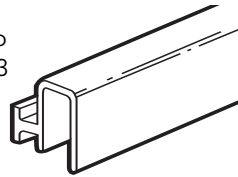

Top door crossbar  
D307

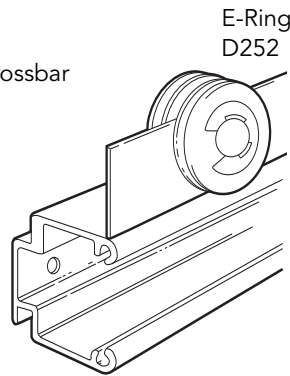

Nylon brush strip  
D840

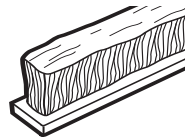

Nylon door glide  
D225

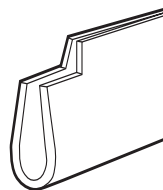

Self tapping screws  
FS6016



Rubber door stop  
D312

Door threshold  
D088 D/D

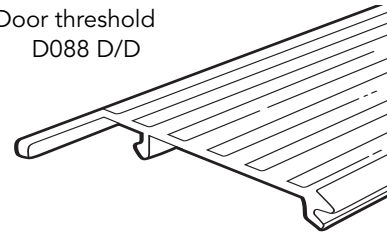

Moulded door track cover  
D204

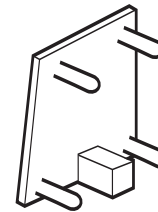

Silicon dispenser syringe type  
D119

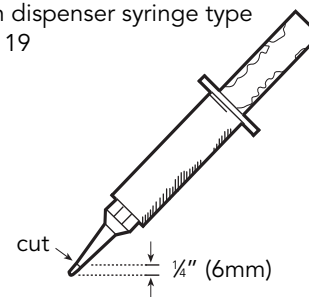

# **Robinsons**

---

## **Premier Aluminium GREENHOUSES**

ROBINSONS GREENHOUSES, STATION WORKS, FENNY COMPTON, SOUTHAM CV47 2XB  
TELEPHONE 01295 770717 · FAX 01295 770819

Whilst the information contained in this leaflet is accurate at the time of publication, changes in the course of Robinsons policy of improvement through development and design might not be indicated. We point out this fact to avoid any infringements of the Trade Descriptions Act and also to advise that Robinsons Greenhouses reserve the right to change specifications and materials without prior notice. All sizes nominal. All weights approximate.